

Ceramic Drinkware from Castles and Earth-and-Timber Fortifications as Indicators of the Medieval Slavonian Nobility's Status

Tkalčec, Tatjana

Source / Izvornik: **Castrum Bene 15, A castle as a status symbol, 2020, 243 - 250**

Conference paper / Rad u zborniku

Publication status / Verzija rada: **Published version / Objavljena verzija rada (izdavačev PDF)**

Permanent link / Trajna poveznica: <https://um.nsk.hr/um:nbn:hr:291:619319>

Rights / Prava: [Attribution-ShareAlike 3.0 Unported](#)/[Imenovanje-Dijeli pod istim uvjetima 3.0](#)

Download date / Datum preuzimanja: **2024-12-27**

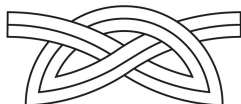

INSTITUT ZA
ARHEOLOGIJU

Repository / Repozitorij:

[RIARH - Repository of the Institute of archaeology](#)



Ceramic drinkware from castles and earth-and-timber fortifications as indicators of the medieval Slavonian nobility's status

Introduction

The paper examines ceramic drinkware from castles and small castles (mottes), e.g. fortified residences of lesser lords and major tenants in medieval Slavonia, placing emphasis on non-majolica cups and beakers, i.e. tableware of local production, due to their great significance for the researched topic and the limited space of the paper.

The *castra* and *castella* from which the discussed material originates are situated in the territory of medieval Slavonian County of Zagorje (castles in Vrbovec, Veliki Tabor, Krapina and Varaždin) and further east in medieval County of Križevci (Garić Castle and the mottes in Torčec, Gudovac, Kutina, Kraljeva Velika, Sokolovac and Tomašica) (Fig. 1). The emphasis is put on Vrbovec Castle, Garić Castle, Gudovec *castellum* and Sokolovac fort (called *Kristalloc castrum*). The material will be compared with more easily available material (in

terms of exploration and publication) from other sites in medieval Slavonia.

The discussion focuses on the late Middle Ages, mainly the 15th and the very beginning of the 16th centuries as the discussed material from that period (mainly) was present at all researched sites. The aim of the paper is to try to establish whether a nobleman's social status can be determined on the basis of the objects which he used in everyday life.

The discussion commences with the thesis that a richer nobleman tried to surround himself with rare and more precious objects. The question arises whether such material can shed a light on his social status. Here we need to examine not only unique, precious items of tableware reflecting the status of his peers and - in particular - of those representing a higher social rank, but also the objects which he chose and ordered at a local workshop, expressing his specific needs, desires and world-view. Another interesting point is to determine



Fig. 1: Castles and small castles in mediaeval Slavonia (Northern Croatia) mentioned in the text: triangle - castle, circle - small castle (lowland hillfort, motte).

whether there are any patterns in the geographical distribution of the locally produced goods, which would point to the regional connections between the nobility.

Archaeological evidence

Vrbovec Castle was a county seat in the 13th century, the centre of an archdeaconry till the modern times, a royal castle and a nobleman's residence dated to the period from the turn of the 12th/13th till 16th centuries. It was owned by Güssing, Cilli, John Vitovec and sons, John Corvinus and the Kotvić family (Karbić 2010). A detailed historical analysis of the sources failed to provide any information about the castle managers (*castellani*), who actually lived there and the aristocrats themselves (e.g. Cilli, the Vitovci family, etc.), who had numerous other castles in their possession and - naturally - can not be expected to have lived in one particular place or at least visited it frequently.

The ceramic cups and beakers from Vrbovec originate from the period of the 13th to 16th centuries. With regard to the archaeological context four groups of ceramic cups (in terms of their chronologically characteristic decoration) were distinguished (Tkalčec 2010, 70-72). The best represented finds belong to the specific group of cups and beakers dated to the second half of the 15th century and the beginning of the 16th century, which is briefly discussed below.

That group is represented by beakers, e.g. cups on foot with bodies shaped like a sandglass, characteristically decorated in the technique of stamping of various motifs. They were made of fine yellow clay and - with one exception - were not glazed. Most of them were found in the layers from the last stage of the life of the medieval castle: in the ground floor of the castle hall (where only a fragment of a green glazed cup was found, see Fig. 2: 6), in the backfill of the medieval cistern and in the yard. Some were found on the western slope outside the castle in the waste layers (Fig. 2).¹ As the medieval castle ceased to function at the end of the 15th century and a new wooden tower was erected in the 16th century on its ruins on the eastern edge of the wall and in the courtyard, it is evident that these cups are to be dated to the second half of the 15th century. The fact that they were found in the 16th century context suggests that the waste finds were for a long time distributed in abandoned Vrbovec Castle, but it is also possible that such cups were still produced and used at the beginning of the 16th century, after the demolition of the medieval castle life briefly returned to it with its new owners - the Kotvić family. These cups are the products of a local workshop. The most similar analo-

gies are the much better preserved specimens found in nearby Veliki Tabor Castle (Škiljan 2007, 83-84, cat. no. 30-36; Škiljan 2012, 135-139, 145-149, T. 2-5), and since Vrbovec and Veliki Tabor may have had the same owner, the question arises whether the same master or workshop supplied both castles with the cups (Fig. 3). The cups made in the same technique, displaying the same motifs were found at some other sites, such as Krapina, Čakovec and Varaždin castles (Šimek, 2008: 40-41, cat. no. 60), but they did not appear to have been made by the same hand.

The cups from Vrbovec with stamped motifs display some similarities to the so-called *Prunkeramik* in Buda, where the group of the rarest white cups was identified (Fig. 2: 7). In Buda, the cups date back to the 1470s and the 1480s (Holl 2005, 371, Abb. 41). Such cups, as well as those glazed in green and similarly decorated (Fig. 2: 6), are rather rare specimens at Slavonian sites, such as Maruševac (Šimek 1999, 57, cat. no. 127) or Torčec (Sekelj Ivančan and Tkalčec 2004, 99, T. 1: 7). They probably represent imported goods, if not from the Buda itself then from the workshops that operated under their influence.

Let us briefly look at the imported drinking tableware from Vrbovec Castle. Two fragments of Loštice beakers produced in Moravian workshops were found in the layers from the 15th and the beginning of the 16th centuries (Fig. 2: 8) together with their glazed imitation (Tkalčec 2015, 71, fig. 14). Several examples of these rather expensive products were found at Slavonian sites. Historical sources provide information that the inventory of Velika Castle (north from Požega) from 1491 possibly featured two Loštice beakers (*peccaria morvay*). For a long time they were considered to mark the southernmost range of their occurrence (Holl 1955, 193) until more such findings were excavated in the area of medieval Slavonia. Besides Vrbovec Castle they were found in Ružica Castle (Radić and Bojčić 2004, 197), Ilok Castle (unpublished finding), Gudovac fort (Tkalčec and Jakovljević 2003, 88) and - which is interesting - at Josipovac-Selište, the site representing a rural settlement (unpublished). Imitations of this type of beaker were excavated in Vrbovec, Garić Castle (Bobovec 2000, 24, fig.) and Gojlo fort (Bobovec 2013, 53, fig., inventory no. 6444Asv).

As far as the dishes for serving drinks from Vrbovec Castle are concerned, bottles were very rare in contrast to frequently found unglazed jugs. Glazing and the red-painted decoration do not seem to be a favourite motif on ceramic cups, bottles or jugs. The products of Italian workshops from the late 15th and early 16th centuries are represented by majolica jugs and a more precious engobed jug made in the technique of graffiti (Zglav-Martinac 2010, 228, 231, fig. 4, fig. 8). Majolica finds were excavated at other sites, mostly in the castles, but also in the strongholds of the lower noble landlords in the County of Križevci.

¹ Here we present only some typical examples, for others, see: Tkalčec 2010, 171-172, cat. no. 259, 260, 263-266, 273-283, 287).

Another trend in the shape and style of decoration of the cups and beakers is obvious in this eastern area. A tummy cup on foot, made in fine or coarse manner, is popular. Many varieties were excavated at different sites, but certain trends and similarities can be recognised, which is particularly interesting to us. Additionally, another type of cups is represented in the east of Slavonia – a more elongated cup on foot, frequently decorated with small clay applications, as exemplified by the finds from Gudovac site and Garić castle.

Historical sources regularly refer to Gudovac as a *castellum* and once as a *castrum*. This telling expression, describing a mere wood and timber fortification, in fact reflects the importance of its owner and his status in the medieval society. It is master (*magister*) Petar de Gudovcz, who during more than 20 years of his political career, was regularly referred to as *egregius* – excellent. His career is almost incredible. He rose from the lower layers of the predials to the echelons of the noble elite. He probably owed it to his own ambitions and close connections with Zagreb bishop Osvald Thuz (maybe through his brother Matija, who was a priest). He went to the court of Matthias Corvinus and Ladislaus II of Hungary. Magister Petar was also the *vice protonotarius* of the Kingdom of Slavonia (to Ulrich Cilli) *vicarius temporalis episcopatus Zagrabiensis*, *vicarius in materialibus* (Tkalčec 2005, 51, Páloszfalvi 2014, 132-140).

In his stronghold in Gudovac master Petar set up a workshop producing stove tiles, modelled on the so-called “the knight-stove” from Buda, and apparently he distributed stove tiles to the owners of the nearby forts as substantiated by the excavations in Grubišno Polje fortification (Tkalčec 2016, 107, fig. 12). Gudovac beakers are cups on unaccentuated foot with rather elongated body emulating the shape of Loštice beakers (Tkalčec 2001, 222-223, fig. 11-13) (Fig. 4: 1).² We can assume that, just like the stove tiles, they were produced in Gudovac fort. Some of these elongated cups are also decorated with applications (Fig. 4: 2). Similar cups on tight foot decorated with applications were found in Garić Castle (Sekelj Ivančan and Tkalčec 2003, 38, T. 1: 1-2) (Fig. 6: 1); at other sites this type of decoration is rather rare, e.g. at Donja Glogovnica and Ivanec Križevački sites (Tkalčec 2001, 221, 224, fig. 6-7, 15).

Beside these, another frequently found type of artefact from Garić is cups on foot with accentuated bellies – some made of very fine clay and decorated with red paintings (Sekelj Ivančan and Tkalčec 2003, 39-40, T. 2: 4-6, T. 3: 1, 3) (Fig. 6: 2). Garić Castle, as an important possession of the bishops of Zagreb with its beakers decorated with applications and fine cups with

² One Loštice beaker found in Gudovac can not be unequivocally described as a genuine product or a very faithful copy, which is a tribute to the skills of a furnace worker from the fort.

red-painted lines, points to some further sites where such artefacts were found (e.g. the already mentioned Donja Glogovnica site); the sites were either directly owned by the bishops of Zagreb or were closely connected with the church – like the cups from the Benedictine monastery at Rudina. Particularly noticeable is the regional eastern circuit, where belly-shaped cups on foot, decorated with red lines, were most popular. Among them stand out those decorated with protruding applications in the form of raspberry or blackberry, resembling the style of the workshops in the Rhine river area. They were found in Rudina monastery (Matijević 2013: 76, cat. no. 22-23), in Kraljeva Velika – the castle of high secular elite (Bobovec 2013, 59, fig., inventory no. A541sv) and in Tomašica fort (Bobovec 2013, 87, fig., inv. no. A261sv). However, the cups were not produced in the West, but they were made in a local workshop, which knew and followed European tableware fashion and styles of decoration, such as the local workshop in Rudina monastery, where a number of belly-shaped cups on foot made of fine yellow clay and decorated with red-lines were found. They include a type of outstandingly decorated cups with religious motifs, found in very large numbers and preserved in more or less complete forms or in fragments. They are decorated with medallions with biblical motifs of the peacock, lamb and lion and the letters IHS (Jesus Hominem Salvator), and additionally decorated with rowel and red horizontal lines as well as with shallow applications in the form of raspberry or blackberry (Sekelj Ivančan 1998, 176-177, T. II, III, Matijević 2013, 77-80, cat. no. 25-43). Besides Rudina, they were found in the fortified church in Mala Črešnjevica near Virovitica (Tkalčec 2001) and at two sites unrelated to the church complex – Kapan Ivanac and Sokolovac (Sekelj Ivančan 1998). They were dated to the second half of the 15th and the beginning of the 16th centuries and are assumed to be the products of a workshop in Rudina monastery (Sekelj Ivančan 1998, 172).

And finally, let us have a look at Sokolovac site, where a fully preserved outstanding cup with biblical motifs was excavated together with a few more fragments of other cups (Fig. 5; Iveković 1968, 372; Bobovec 1986, 143; Bobovec 2013, 84-86). In the 15th century Sokolovac or *Kristalloc castrum* was in possession of the second generation of the Kristalloci family. After a brief ownership of John Vitovc in the 1480s it was acquired by powerful Ladislav Hermanfi de Greben, who was twice a deputy ban of Slavonia. In 1490 all of his possessions, including Kristalovac Castle, were inherited by his son-in-law, Balthazar Batthyany (Páloszfalvi 2014, 199-202). Neither historical sources nor archaeological excavations carried out in 1966 gave a satisfactory answer to the question who exactly owned the cups or which *castellani* used them. In addition to the beakers decorated with biblical motifs on medallions, archaeological excavations at Sokolovac revealed numerous



Fig. 2: Vrbovec Castle, medieval County of Zagorje: 1-7. selection of ceramic cups with stamped motifs, 8. Loštice beakers (photo by Tatjana Tkalčec).



Fig. 3: Ceramic cups with stamped motifs from Veliki Tabor Castle, medieval County of Zagorje (after Škiljan 2012, 137).



Fig. 4: Ceramic cups from Gudovac-Gradina fortification, medieval County of Križevci (photo by Tatjana Tkalčec).



Fig. 5: Ceramic cup with biblical motifs from Sokolovac fortification (photo by Tajana Sekelj Ivančan).

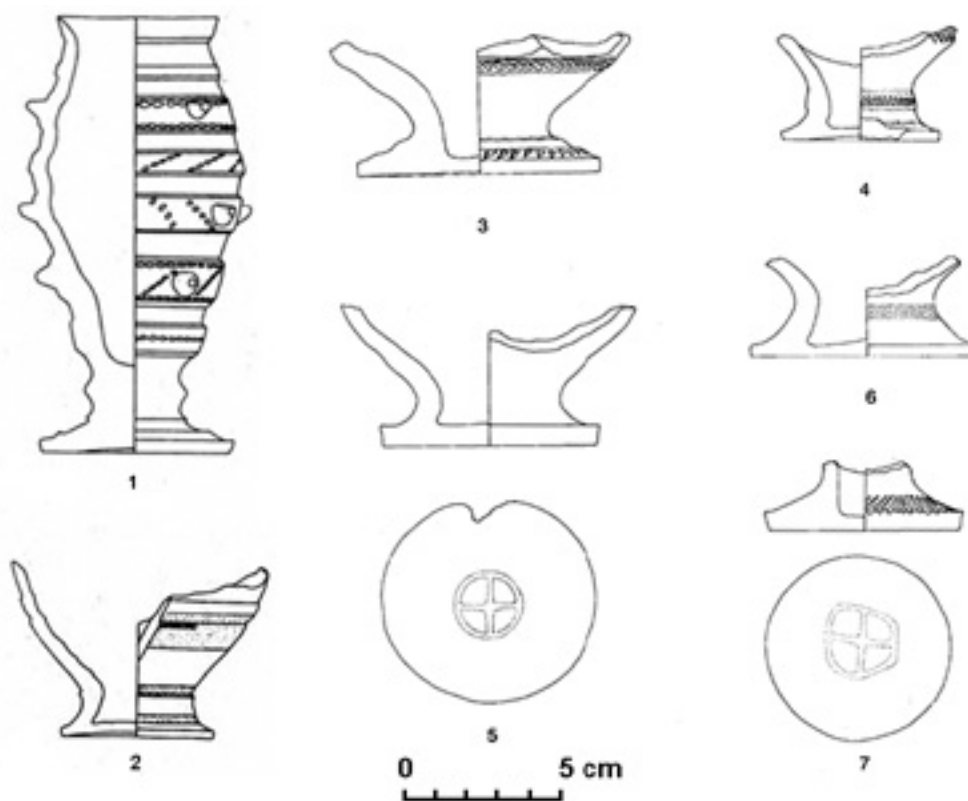

Fig. 6: Ceramic cups from Garić Castle and Sokolovac fortification, medieval County of Križevci: 1-2. Garić Castle (after Sekelj Ivančan, Tkalčec 2003, 38, T. 1: 2), 3-7. Sokolovac (after Sekelj Ivančan, Tkalčec 2002, 188, T. 3: 3-7).

cups and their fragments which look like the ones found at former sites – fine yellow cups on foot with accentuated bellies, sometimes decorated with red lines (Fig. 6: 3-7; Sekelj Ivančan and Tkalčec 2002, 186-190, T. 1: 1, T. 2: 6, T. 3: 2-7). They must have influenced Ružica Castle situated further east, where several examples of brownish cups made of more coarse clay and decorated in such a manner were excavated (Radić and Bojčić 2004, cat. nos. 379-384).

Furthermore, the excavations in Sokolovac provided several examples of beakers, whose slender elongated body and emphasized narrow foot resemble the beakers from Gudovac and Garić Castle, although in Sokolovac they were not decorated with circuit applications (Bobovec 2013, 85, fig., inv. no. A99sv). A specific decoration with a series of horizontal ribs is evident in the specimens from Sokolovac (Sekelj Ivančan and Tkalčec 2002, 181, T. 5: 1), which is also present in the artefacts excavated in Garić (Sekelj Ivančan and Tkalčec 2003, 39, T. 2: 1-2). Almost identical cups were found in Kutina-Turski stol hillfort (Sekelj Ivančan and Tkalčec 2002, 181, T. 5: 2-3; Bobovec 2013: 67, fig., inv. no. A60sv). With their more or less accentuated (convex) belly form and the style of decoration all these cups clearly differ from the chalice formed (concave as a sandglass) beakers decorated with stamped motifs – the most popular type of beaker found in the castles in the western circuit of the medieval Kingdom of Slavonia.

Discussion

The area of the medieval Hungarian-Croatian Kingdom, and thus the territory of the Kingdom of Slavonia, is part of the so-called „lands of numerous nobility“, where the nobility represented a higher percentage of the entire population than in the Christian West. The nobility, therefore, played an important role in the social and political life of medieval Slavonia (Karbić 1998, 73; Miljan 2014, 104). In this sense the County of Zagorje was the territory where nobility was not strongly represented, unlike the County of Križevci. Aristocracy or middle noble elite owned several castles (*castra*) in the County of Zagorje, where, the judicial power was exercised by the *ban*. Unlike in the County of Križevci, besides several castles there were a number of smaller fortified manors. The historical sources from the 15th century mostly refer to the fortifications as *castella*. The backbone of the Kingdom of Slavonia (*Regnum Sclavoniae*) was actually created by the self-governing Counties of Križevci and Zagreb, where the major (*comes*) shared the judicial power with four noble landowners and two castle officers (*iobagiones castr*). They were elected by the General Assembly of the landowners (*congregation generalis*), which was controlled and supervised personally by the *ban* (Margetić 2000, 93).

The secular nobility was divided into aristocracy and the highest nobility, and then the middle and lower

nobility. A similar stratification of the ecclesiastic segment of the society can be observed, where the highly positioned clergy also had a distinct social status. All of them were more or less directly involved in the production and exchange of goods and objects of material culture characteristic of the separated, higher social stratum.

The late medieval nobility from medieval Križevci County has been thoroughly researched. Engel Pál's research of the nobility from County Ung was further complemented by a similar synthesis of nobility of the County of Körös (Križevci) published by Tamás Páloszfalvi. His work covers the period from the 15th century until 1526, which coincides with the period which the archaeological finds of tableware from all the sites analysed here are dated to. Páloszfalvi points out that the erection of a *castellum* type of fort can be directly linked with the elite layer of the middle nobility. He also gives a list of *castra* and *castella* (Páloszfalvi 2014: 321–330); however, some of the excavated fortifications were not mentioned in the historical sources from that late period. Of course, the reason could be the poor condition of the surviving historical documents, but it is also possible that the owners of these fortifications were somewhat less prominent nobles. The distribution of such small castles dated to the 15th and the beginning of the 16th century in the County of Križevci shows a greater number of sites that cannot be linked to the nobility known from the historical sources. A good example here is Sokolovac fort, whose owners are mentioned in the sources, Tomašica fort situated one kilometer away, which on the basis of current knowledge can not be attributed to any noble family from the elite stratum of middle nobility (Sekelj Ivančan and Tkalčec 2002, 167, 174–176, Map 2, Fig. 6, 6a, 6b, 7, 7a, 7b).

In this sense ceramic tableware is of exceptional importance for the research of different segments of the high and late Middle Ages. It lends itself to chronological classification and, if found in clear archaeological contexts, the tableware constitutes a convenient point of reference in typological-chronological analyses of other material escaping easy classification acquired in the same layers as well as in further stratigraphic analyses of different layers and contexts at a single site. Unfortunately, clear information on archaeological context is not always available for all of the sites discussed here. However, the value of the tableware in archaeological analyses surpasses its mere typological-chronological significance because it offers a wealth of valuable data in the examination of the social status of the residents of castles and other fortified noble residences as well as their social interrelations.

When the locally produced tableware from the analysed castles and hillforts is examined, the specific character of each site becomes evident, but some common trends in the use of various kinds of tableware of local production can also be seen. Certain patterns in

geographical distribution of specific kinds of cups and beakers can be recognised, which coincides with the boundaries of two different counties of medieval Slavonia. Locally produced ceramic cups and beakers most popular in the western circle, i.e. the County of Zagorje, differ from those most fashionable in the eastern circuit, in the County of Križevci.

The distribution of the cups of similar forms, produced and decorated in local workshops testifies to horizontal links between the nobility, e.g. Vrbovec Castle and Veliki Tabor Castle in the west of Slavonia. Similarities of forms and ways of decorating cups can also be seen in the eastern parts of Slavonia, e.g. at the sites in Sokolovac, Kraljeva Velika and Tomašica, or in Garić and Gudovac. The sites in the County of Križevci were strongly influenced by the fashion and trends originating in Buda, the centre of the Kingdom, as is the case of Gudovac fort. Historically confirmed links between the owners of some Slavonian castles with Buda are distinctly reflected in the archaeological material, as exemplified by locally produced goods and imports.

We can assume that costly tableware from even more distant workshops (e.g. Loštice beakers and Italian majolica) indirectly ordered through Buda also reached Slavonian castles. The castles in the very west of Slavonia, in the County of Zagorje, could have followed western trends directly, but these influences have not been clearly recognized. Although the stamped beakers from Vrbovec Castle and Veliki Tabor Castle display certain similarities with the so-called Celje type of beakers (Guštin 2001, 158), they were not contemporary. At the sites discussed here they were found in the layers which were several decades younger.

Since we can assume that the ceramic cups with stamped motifs from Vrbovec Castle and Veliki Tabor Castle originated from the same local workshop, similar assumptions can be made for the sites from the eastern circuit. Sokolovac, Garić and Kutina-Turski stol have provided elongated cups decorated with series of ribs, which were most probably produced in the same workshop. The fine belly-form cups with biblical motifs found at Sokolovac, Kapan Ivanac and Mala Črešnjevica from the eastern part of Kingdom of Slavonia are connected with the workshop in Rudina monastery. Rudina with its belly-formed cups decorated with rowel, red horizontal lines and raspberry applications is connected with Tomašica and Kraljeva Velika, again the sites in the same eastern circuit.

Although indirect foreign influences are recognizable, all the tableware is a product of domestic workshops, which on the one hand emulated general stylistic trends in decorating ceramic cups and beakers, but on the other, gave them a specific local character.

The analysis of the locally produced drinkware gave affirmative answers to the questions raised in the introduction to this paper and thus it can be concluded that the tableware of local production is a remarkable

source for the study of the social status and relationships of local nobility, owners and residents of fortified residences, i.e. *castra* and *castella*, and that great potential offered by the materials from medieval Slavonia has not yet been exhausted.

Dr. Tatjana Tkalčec
Institut za Arheologiju
(Institute of Archaeology)
Jurjevska 15, Zagreb, Croatia
ttkalcec@iarh.hr
ORCID 0000-0003-3963-7706

References:

- Bobovec, Ana 1986, Sokolovac, Garešnica. - In: *40 godina arheoloških istraživanja u sjeverozapadnoj Hrvatskoj*, ed. by group of authors, Muzejsko društvo sjeverozapadne Hrvatske, Koprivnica, pp. 143.
- Bobovec, Ana 2000, Arheologija. - In: *40 godina Muzeja Moslavine*, ed. by Mladen Mitar, Muzej Moslavine Kutina, Kutina, pp. 15-24.
- Bobovec, Ana 2013, *Arheologija u Moslavini*. - Muzej Moslavine Kutina, Kutina.
- Guštin, Mitja 2001, Celjske čaše. Srednjeveške in zgodnjenovoveške lončene čaše na Slovenske. - In: *Srednjeveško Celje*, ed. by Mitja Guštin, (Archaeologia Historica Slovenica 3), Oddelek za arheologijo, Filozofska fakulteta, Univerza v Ljubljani, Ljubljana, pp. 139-193.
- Holl, Imre 1955, Külföldi kerámia Magyarországon (XIII-XVI. század). (Ausländische Keramikfunde des 13. bis 16. Jahrhunderts in Ungarn). - *Budapest Régiségei* 16, pp. 147-197.
- Holl, Imre 2005, Tischgerät im spätmittelalterlichen Buda. Archäologische Angaben und deren Schranken. - *Acta Archaeologica Academiae Scientiarum Hungaricae* 56, pp. 311-384.
- Iveković, Dragica 1968, Rezultati sondažnih arheoloških istraživanja na području Moslavine. - *Zbornik Moslavine* 1, Kutina, pp. 349-378.
- Karbić, Damir 2010, Povijesni podaci o burgu Vrbovcu (1267.-1524.). - In: *Burg Vrbovec u Klenovcu Humskome. Deset sezona arheoloških istraživanja*, by Tatjana Tkalčec, Institut za arheologiju, Zagreb, pp. 203-222.
- Margetić, Lujo 2000, *Zagreb i Slavonija. Izbor studija*. - Hrvatska akademija znanosti i umjetnosti, Zagreb - Rijeka.
- Matijević, Marijana 2013, Gotičke keramičke čaše iz rudine. - *Radovi Zavoda za znanstveni i umjetnički rad u Požezi* 2 (2013), pp. 61-86.
- Páloszfalvi, Tamás 2014. *The Noble Elite in the County of Körös (Križevci) 1400-1526*. - MTA Bölcsészettudományi Kutatóközpont Történettudományi Intézet, Budapest.
- Radić, Mladen and Bojčić, Zvonko 2004, *Srednjovjekovni grad Ružica*. - Muzej Slavonije Osijek, Osijek.
- Sekelj Ivančan, Tajana 1998, Kasnosrednjovjekovne keramičke čaše iz Sokolovca, Rudina - Čečavca i Kapan - Ivanca. - *Prilozi Instituta za arheologiju u Zagrebu* 13-14/1996-1997 (=1998), pp. 161-177.
- Sekelj Ivančan, Tajana and Tkalčec, Tatjana 2002, Kasnosrednjovjekovna stolna keramika s nekih gradišta iz okolice Kutine i Garešnice. - *Prilozi Instituta za arheologiju u Zagrebu* 19, pp. 165-194.
- Sekelj Ivančan, Tajana and Tkalčec, Tatjana 2003, Kasnosrednjovjekovni lokaliteti okolice Kutine i Garešnice s posebnim obzirom na neke primjerke stolne keramike iz Garić-grada i Popovače. - *Zbornik Moslavine* 5-6 (2002/2003), pp. 25-44.
- Sekelj Ivančan, Tajana and Tkalčec, Tatjana 2004, Arheološko nalazište Torčec-Gradić. - *Podravina, Časopis za multidisciplinarna istraživanja* 3/6, pp. 71-106.
- Šimek, Marina 1999, Kataložki popis. - In: *Spomenka Težak, Marina Šimek and Tomislav Lipljin, Županija varaždinska u srednjem vijeku*. - Gradski muzej Varaždin, Varaždin, pp. 40-47.
- Šimek, Marina 2008, Popis kataložkih jedinica izložbe. - In: *Iz srednjeg u novi vijek. Varaždinski Stari grad i projekt Bastion/Iz srednjega v novi vek. Varaždinski Stari grad in projekt Bastion/From the Middle Ages to the Modern World. Varaždin Old Town and the Project Bastion*, ed. by Miroslav Klemm, Marina Šimek and Spomenka Težak, Gradski muzej Varaždin, Varaždin, pp. 35-52.
- Škiljan, Ivana 2007, Veliki Tabor u svjetlu arheoloških otkrića. - In: *Tabor u svjetlu otkrića/Veliki Tabor in light of discovery*, ed. by Goranaka Horjan, Muzeji Hrvatskog zagorja, Gornja Stubica, pp. 35-117.
- Škiljan, Ivana 2012, Kasnogotičke keramičke čaše i neki primjeri stolne keramike iz dvorca Veliki Tabor. - In: *Tajanstvena gotika - Veliki Tabor i kapela sv. Ivana*, ed. by Nadica Jagarčec, Muzeji Hrvatskog zagorja, Gornja Stubica, pp. 132-152.
- Tkalčec, Tatjana 2001, Arheološko istraživanje crkve Sv. Martina u Maloj Črešnjevici kraj Pitomače u godini 2001. - *Obavijesti Hrvatskog arheološkog društva* 34/1, pp. 99-103.
- Tkalčec, Tatjana 2001a, Gotičke keramičke čaše iz Glogovnice i Ivanca Križevačkog kraj Križevaca i Gudovca kraj Bjelovara. - *Prilozi Instituta za arheologiju u Zagreb* 18, pp. 213-234.
- Tkalčec, Tatjana 2005, Gudovac - Gradina 2004. - *Annales Instituti Archaeologici* 1, pp. 50-55.
- Tkalčec, Tatjana 2010, *Burg Vrbovec u Klenovcu Humskome. Deset sezona arheoloških istraživanja*. - Institut za arheologiju, Zagreb.
- Tkalčec, Tatjana 2015, Novi pogledi na stara obrambena zdanja: burg Vrbovec u Klenovcu Humskom, arheološka istraživanja 2014. godine. - *Annales Instituti Archaeologici* 11, pp. 63-73.

Tkalčec, Tatjana 2016, Kasnosrednjovjekovni arheološki kompleks Grubišno Polje - Šuma Obrovi - probna arheološka istraživanja u 2015. - *Annales Instituti Archaeologici* 12, pp. 99-112.

Tkalčec, Tatjana and Jakovljević, Goran 2003, Prva sezona istraživanja srednjovjekovnog gradišta Gudovac-Gradina. - *Obavijesti Hrvatskog arheološkog društva* 35/2, pp. 85-89.

Zglav-Martinac, Helga 2010, Kasnosrednjovjekovna i novovjekovna keramika s premazom s lokaliteta Plemički grad Vrbovec. - In: *Burg Vrbovec u Klenovcu Humskome. Deset sezona arheoloških istraživanja*, by Tatjana Tkalčec, Institut za arheologiju, Zagreb, 223-233.

Tatjana Tkalčec

Keramische Trinkware von den Burgen und Erd-Holz-Befestigungen als Kennzeichen vom mittelalterlichen slowenischen Adelsstatus

Im vorliegenden Beitrag wird das Keramikgeschirr, zum Trinken von Getränken, aus Burgen und befestigten Residenzen von Eliten des Mitteladels und der kleineren Herren auf dem Gebiet des mittelalterlichen Slawonien behandelt. Der Schwerpunkt liegt auf dem Geschirr lokaler Produktion, also auf Tassen und Bechern, während die Ergebnisse von importiertem Geschirr, das aus analysierten Fundorten und Gebieten stammt, nur kurz angegeben werden.

Der Beitrag ist auf die Zeit des späten Mittelalters, vor allem des 15. und Anfang des 16. Jahrhunderts fokussiert, beziehungsweise auf den Horizont, der an allen untersuchten Lokalitäten erkannt und besser erforscht wurde. Die Arbeit setzt sich zum Ziel einen Versuch zu sehen, ob wir aus diesen von Adligen im täglichen Leben verwendeten Gegenständen mehr über ihren sozialen Status erfahren können. Weiterhin, ob wir irgendwelche Muster bei der Distribution der Güter lokaler Produktion erkennen können. Die Analyse des Materials gab positive Antworten auf diese Fragen und es kann geschlussfolgert werden, dass das Geschirr lokaler Produktion eine außerordentliche Quelle für die Untersuchung des Status, der Beziehungen und Verbindungen des lokalen Adels ist, und dass das große Potential dieser Materialien auf dem Gebiet des mittelalterlichen Slawonien noch bei weitem nicht erschöpft ist.

Castrum Bene 15
A castle as a status symbol
Studia Castellologica I

“Castrum Bene” Permanent Committee and Editorial Board:

PhDr. Peter Bednár, CSc., Archeologický ústav SAV

Dr Artur Boguszewicz, Uniwersytet Wrocławski, Wydział Nauk Historycznych i Pedagogicznych,
Katedra Etnologii i Antropologii Kulturowej

Dr. István Feld, Eötvös, Loránd University, Faculty of Humanities, Institute of Archaeological Sciences

PhDr. Zlata Gersdorfová Ph.D., Západočeská univerzita v Plzni, Filozofická fakulta, Katedra archeologie

Mag. Dr. Martin Krenn, Bundesdenkmalamt, Abteilung für Archäologie

Doc. Dr. Silvija Pisk, Filozofski fakultet Sveučilišta u Zagrebu

Doc. Dr. Katarina Predovnik, Univerza v Ljubljani, Filozofska fakulteta, Oddelek za arheologijo

Dr. Adrian Andrei Rusu, Institutul de arheologie și istoria artei al Academiei Române

Castrum Bene 15

A castle as a status symbol

Edited by Artur Boguszewicz and Janina Radziszewska



Studia Castellologica I



Uniwersytet
Wrocławski

Wrocław 2020

“Studia Castellologica” Programme Board:

Dagmara Adamska

Aleksander Andrzejewski

Artur Boguszewicz

Małgorzata Chorowska

Mateusz Goliński

Piotr Lasek

Anna Marciniak-Kajzer

Dominik Nowakowski

Jerzy Piekalski

Kazimierz Pospieszny

Janina Radziszewska

Jan Salm

Marcin Wiewióra

Studia Castellologica I

A castle as a status symbol

Edited by Artur Boguszewicz and Janina Radziszewska



Castrum Bene 15

Castrum Bene 15
Studia Castellologica I
A castle as a status symbol

Edited by:

Artur Boguszewicz and Janina Radziszewska

Reviewers:

dr hab. Anna Kajzer prof. UŁ.

dr Martin Rundkvist assoc. res. prof.

dr hab. inż. arch. Jan Salm prof. PŁ

Proofreading:

Bartłomiej Madejski, Janusz Murczkiewicz

© Copyright by the University of Wrocław and authors

“Studia Castellologica” Logo Image by Nicole Lenkow

Studia Castellologica I
ISBN 978-83-939353-3-8

Castrum Bene 15
ISBN 978-83-939353-6-9

Published by:



University of Wrocław
Faculty of Historical and Pedagogical Sciences
Department of Ethnology and Cultural Anthropology
50-139 Wrocław, ul. Szewska 50/51, tel./fax: +48-713430553
<http://www.etnologia.uni.wroc.pl>

Printed by: Quaestio

In memoriam
Profesor doktor habilitowany Leszek Kajzer *11.08.1944 - † 25.09.2016



The volume is dedicated to the memory of Leszek Kajzer - our dear friend, colleague, teacher and member of the Permanent Committee of Castrum Bene for many years.

Photo by Aldona Andrzejewska

Contents

Artur Boguszewicz	
From Castrum Bene 15 to Studia Castellologica I. Results and research perspectives	13
Janusz Pietrzak und Aleksander Andrzejewski	
Professor Dr. habil. Leszek Kajzer – ein Burgenforscher	21
Artur Boguszewicz and Janina Radziszewska	
Castles – a symbolic reflection of social status	39

Castle - power - territory

Małgorzata Chorowska	
The Castles of Henries – the Dukes of Silesia as status symbols	47
Patrick Schicht	
Kastelle, ein Baukonzept der Fürsten	61
Luboš Hobl	
The Přemyslid castles and Teutonic Order's castles: another perspective on the issue of the relation	69
Silvija Pisk	
<i>Honor banatus</i> und die kroatischen Burgen	75

Symbol - status - form

Petr Chotěbor	
Festen und kleine Burgen als Statussymbol	85
Kazimierz Pospieszny	
Die Haupttürme der „klassischen“ Deutschordensburgen in Preußen – Funktionen und Bedeutung	95
Zlata Gersdorfová	
<i>Curia, oppidum, castrum...</i>	
Die Sitze der Herren von Krummau im Lichte der schriftlichen Quellen und Archäologie	107
Szabolcs Balázs Nagy	
Social display at the centres of noble households: courtyards of 14-15 th -century Hungarian castles	119
Dominik Nowakowski	
Die Motten Schlesiens im Lichte archäologischer und schriftlicher Quellen	129
Petr Kastl und Zlata Gersdorfová	
Adelsresidenz, Festung oder Ruine? Drei Gestalten der mittelalterlichen Burg in der frühen Neuzeit an Beispielen aus dem bayerisch-tschechischen Grenzgebiet	147

Case studies

Christofer Herrmann	
Hierarchie und Rangordnung in der Architektur des Hochmeisterpalastes auf der Marienburg	157
Dóra Hegyi	
The Red Tower of Sárospatak - the status symbol of a Hungarian nobleman in the 16 th century	167
Anna Łuczak und Jerzy Piekalski	
Kynast/Chojnik - die erste Burg der Familie Schaffgotsch	177
Peter Bednár, Drahoslav Magdoško and Michal Šimkovic	
Košice - an unfinished castle project	185
Piotr Lasek	
The tower of a humble priest. The habitat of Kasper Sadłocha and Polish manors in the 16 th century	199
Andrej Janeš	
Construction and location as a sign of social status: the case of a high medieval <i>motte</i> of Turčišće - Gradišće in Međimurje (north Croatia)	209
Oana Toda	
Built Features of Rupea Castle during the Early Modern Period. The Houses and Rooms from the Upper and Middle Precincts	221

Everyday life - habitus - status

Felix Biermann	
Metallene Zeugen adeliger Statusdemonstration auf mittelalterlichen Befestigungen in Brandenburg	231
Tatjana Tkalčec	
Ceramic drinkware from castles and earth-and-timber fortifications as indicators of the medieval Slavonian nobility's status	243
Artur Boguszewicz	
Auf der Suche nach der Adelskultur. Das Beispiel Burgen in Schlesien	251