

# Grobovi certoškoga stupnja u stariježeljeznodobnom tumulu 48 u Stični

---

**Božič, Dragan**

*Source / Izvornik:* **Prilozi Instituta za arheologiju u Zagrebu, 2016, 33, 155 - 170**

**Journal article, Published version**

**Rad u časopisu, Objavljena verzija rada (izdavačev PDF)**

*Permanent link / Trajna poveznica:* <https://um.nsk.hr/um:nbn:hr:291:340366>

*Rights / Prava:* [Attribution 3.0 Unported](#)/[Imenovanje 3.0](#)

*Download date / Datum preuzimanja:* **2025-01-31**



INSTITUT ZA  
ARHEOLOGIJU

*Repository / Repozitorij:*

[RIARH - Repository of the Institute of archaeology](#)



UDK 902  
ISSN 1330-0644  
VOL 33/2016.  
ZAGREB, 2016.

# Prilozi

Instituta za arheologiju u Zagrebu

Pril. Inst. arheol. Zagrebu, 33/2016  
Str./Pages 1-352, Zagreb, 2016.

Izdavač/Publisher  
INSTITUT ZA ARHEOLOGIJU  
INSTITUTE OF ARCHAEOLOGY

Adresa uredništva/Address of the editor's office  
Institut za arheologiju/Institute of archaeology  
HR-10000 Zagreb, Ulica Ljudevita Gaja 32  
Hrvatska/Croatia  
Telefon/Phone ++385/(0)1 61 50 250  
Fax ++385(0)1 60 55 806  
e-mail: urednistvo.priloz@iarh.hr  
<http://www.iarh.hr>

Glavni i odgovorni urednik/Editor in chief  
Marko DIZDAR

Uredništvo/Editorial board  
Marko DIZDAR, Snježana KARAVANIĆ, Viktória KISS (Budapest, HUN) (prapovijest/Prehistory),  
Marija BUZOV, Goranka LIPOVAC VRKLJAN (antika/Antiquities), Katarina Katja PREDOVNIK  
(Ljubljana, SLO), Natascha MEHLER (Wien, AUT), Juraj BELAJ, Tatjana TKALČEC (kasni srednji  
vijek i novi vijek/Late Middle Ages and Modern era), Predrag NOVAKOVIĆ (Ljubljana, SLO)  
(metodologija/Methodology)

Izdavački savjet/Editorial advisory board  
Dunja GLOGOVIĆ (Zagreb), Ivor KARAVANIĆ (Zagreb), Timotej KNIFIC (Ljubljana,  
SLO), Laszlo KÓVACS (Budapest, HUN), Kornelija MINICHREITER (Zagreb),  
Mladen RADIĆ (Osijek), Aleksandar RUTTKAY (Nitra, SK), Ivančica  
SCHRUNK (Minneapolis, USA), Željko TOMIČIĆ (Zagreb), Ante UGLEŠIĆ (Zadar)

Prijevod na engleski/English translation  
Sanjin MIHELIC, Dragan BOŽIĆ, Ana ĐUKIĆ, Heidy ETEROVIĆ, Ana GRABUNDŽIJA,  
Igor KULENOVIĆ, Tamara LEVAK POTREBICA, Marko MARAS, Krešimir MIJIĆ

Prijevod na hrvatski/Croatian translation  
Sanjin MIHELIC

Prijevod na njemački/German translation  
Mario GAVRANOVIĆ

Lektura/Language editor  
Ivana MAJER (hrvatski jezik/Croatian)  
Sanjin MIHELIC, Tamara LEVAK POTREBICA, Marko MARAS, Emily ZAVODNY  
(engleski jezik/English)  
Mario GAVRANOVIĆ (njemački jezik/German)

Korektura/Proofreads  
Katarina BOTIĆ  
Marko DIZDAR

Grafičko oblikovanje/Graphic design  
Roko BOLANČA

Računalni slog/Layout  
Hrvoje JAMBREK

Tisak/Printed by  
Tiskara Zelina d.d., Sv. I. Zelina

Naklada/Issued  
400 primjeraka/400 copies

## Sadržaj

## Contents

### Izvorni znanstveni radovi

### Original scientific papers

- |     |  |   |
|-----|--|---|
| 5   | ANDREJA KUDELJIĆ<br>Kurilovec – Belinščica – bronzanodobno naselje u<br>Turopolju  | ANDREJA KUDELJIĆ<br><i>Kurilovec – Belinščica – A Bronze Age Settlement<br/>in the Turopolje Region</i>   |
| 53  | IGOR KULENOVIĆ<br>Kasnobrončanodobno naselje Podgajac – Glogovica<br>kod Slavonskog Broda  | IGOR KULENOVIĆ<br><i>A Late Bronze Age Settlement Podgajac –<br/>Glogovica near Slavonski Brod</i>  |
| 89  | MARIO GAVRANOVIĆ<br>ALEKSANDAR JAŠAREVIĆ<br>Neue Funde der Spätbronzezeit aus Nordbosnien  | MARIO GAVRANOVIĆ<br>ALEKSANDAR JAŠAREVIĆ<br><i>Novi nalazi kasnoga bronzanog doba iz sjeverne<br/>Bosne</i>   |
| 133 | DARIA LOŽNJAK DIZDAR<br>PETRA RAJIĆ ŠIKANJIĆ<br>O pogrebnim običajima u 11. st. pr. Kr. na jugu<br>Karpatske kotline<br>(primjer: groblje u Slatini) | DARIA LOŽNJAK DIZDAR<br>PETRA RAJIĆ ŠIKANJIĆ<br><i>On Burial Practices in the Southern Carpathian<br/>Basin in the 11<sup>th</sup> Century BC<br/>(Case Study: Cemetery in Slatina)</i> |
| 155 | DRAGAN BOŽIČ<br>Graves from the Certosa Phase in Early Iron Age<br>Barrow 48 at Stična   | DRAGAN BOŽIČ<br><i>Grobovi certoškoga stupnja u<br/>stariježeljznodobnom tumulu 48 u Stični</i>   |
| 171 | TAJANA SEKELJ IVANČAN<br>TENA KARAVIDOVIĆ<br>Tkalački stan iz Virja  | TAJANA SEKELJ IVANČAN<br>TENA KARAVIDOVIĆ<br><i>A Loom from Virje</i>   |
| 237 | SILVIA BEKAVAC<br>ŽELJKO MILETIĆ<br>Stanovnicima Narone – <i>municipibus municipii</i>   | SILVIA BEKAVAC<br>ŽELJKO MILETIĆ<br><i>To the Inhabitants of Narona – municipibus municipii</i>   |
| 247 | JURAJ BELAJ<br>MARIJANA BELAJ<br>Prstenasti broš s natpisom iz templarske Gore –<br>prijedlog dekodiranja  | JURAJ BELAJ<br>MARIJANA BELAJ<br><i>An Inscribed Annular Brooch from the Templar Site of<br/>Gora – A Possible Decipherment</i>   |

## Prethodno priopćenje

- 271 IVOR KARAVANIĆ  
NIKOLA VUKOSAVLJEVIĆ  
NATALIJA ČONDIĆ  
SLOBODAN MIKO  
IVAN RAZUM  
NIKOLINA ILIJANIĆ  
KRUNOSLAV ZUBČIĆ  
RAJNA ŠOŠIĆ KLINDŽIĆ  
JAMES C. M. AHERN  
ANTONELA BARBIR  
Projekt „Kasni musterijen na istočnom Jadranu – temelj za razumijevanje identiteta kasnih neandertalaca i njihovog nestanka”: sažetak 2. i 3. godine istraživanja

- 287 ANA GRABUNDŽIJA  
CHIARA SCHOCH  
AGATA ULANOWSKA  
Kosti za tkalački stan. Eksperiment tkanja s astragalima

- 307 RENATA ŠOŠTARIĆ  
HRVOJE POTREBICA  
NIKOLINA ŠAIĆ  
ANTONELA BARBIR  
Prilog poznavanju halštatskih pogrebnih običaja – arheobotanički nalazi tumula 13 i 14 iz Kaptola kraj Požege

## Pregledni rad

- 317 AGATA ULANOWSKA  
Towards Methodological Principles for Experience Textile Archaeology.  
Experimental Approach to the Aegean Bronze Age Textile Techniques in the Institute of Archaeology, University of Warsaw

## Recenzije

- 341 KREŠIMIR MIJIĆ  
Aleksandra Nikoloska i Sander Müskens (eds.), Romanising Oriental Gods?, Međunarodni znanstveni skup Skopje, 18.–21. rujna 2013., Skopje, 2015, 440 str.

- 345 UPUTE AUTORIMA

## Preliminary communication

- IVOR KARAVANIĆ  
NIKOLA VUKOSAVLJEVIĆ  
NATALIJA ČONDIĆ  
SLOBODAN MIKO  
IVAN RAZUM  
NIKOLINA ILIJANIĆ  
KRUNOSLAV ZUBČIĆ  
RAJNA ŠOŠIĆ KLINDŽIĆ  
JAMES C. M. AHERN  
ANTONELA BARBIR  
*Project Late Mousterian in the Eastern Adriatic – Towards Understanding of Late Neanderthals' Identity and Their Demise: Summary of the 2<sup>nd</sup> and 3<sup>rd</sup> Years of Research*

- ANA GRABUNDŽIJA  
CHIARA SCHOCH  
AGATA ULANOWSKA  
*Bones for the Loom. Weaving Experiment with Astragali Weights*

- RENATA ŠOŠTARIĆ  
HRVOJE POTREBICA  
NIKOLINA ŠAIĆ  
ANTONELA BARBIR  
*A Contribution to the Understanding of Hallstatt Burial Customs – Archaeobotanical Evidence from Tumuli 13 and 14 at the Site of Kaptol, near Požega*

## Report

- AGATA ULANOWSKA  
*Prilozi metodološkim principima u iskustvenoj tekstilnoj arheologiji.*  
*Eksperimentalni pristup tekstilnim tehnikama bronzanog doba Egeje na Institutu za arheologiju Sveučilišta u Varšavi*

## Book reviews

- KREŠIMIR MIJIĆ  
*Aleksandra Nikoloska and Sander Müskens, Romanising Oriental Gods?, International Symposium Skopje, 18–21 September 2013, Skopje, 2015, 440 p.*

- GUIDELINES FOR CONTRIBUTORS

# Graves from the Certosa Phase in Early Iron Age Barrow 48 at Stična

## Grobovi certoškoga stupnja u stariježeljeznodobnom tumulu 48 u Stični

Izvorni znanstveni rad  
Prapovijesna arheologija

*Original scientific paper  
Prehistoric archaeology*

UDK/UDC 903.5(497.4 Stična)“6387”

Primljeno/Received: 25. 02. 2016.

Prihvaćeno/Accepted: 12. 09. 2016.

DRAGAN BOŽIČ  
Znanstvenoraziskovalni center SAZU  
Inštitut za arheologijo  
Novi trg 2  
SI-1000 Ljubljana  
Slovenija  
dragan.bozic@zrc-sazu.si

*In his study on the Hallstatt barrows from Stična published in the monograph Stična II/2 (Ljubljana 2010), Stane Gabrovec presented in Figure 21 a table and in Figure 23 a ground plan with typical graves from four chronological phases in barrow 48. He assigned only twelve graves, all but one female, to the fourth phase, which should correspond to the Certosa phase of the Dolenjska group of the Hallstatt culture. Four of these, however, are in reality earlier. On the other hand, at least twenty-eight other Certosa phase graves from barrow 48, both female and male, should be added to the eight correctly dated graves from the fourth phase. Some of them are very rich, and have high potential for a new typological and chronological analysis of this phase.*

*Keywords: Slovenia, Stična, Early Iron Age, barrow 48, Hallstatt culture, Dolenjska group, chronology, Certosa phase*

*U svojoj studiji o halštatskim tumulima iz Stične objavljenoj u monografiji Stična II/2 (Ljubljana 2010), Stane Gabrovec na slici 21 predstavio je tablicu i na slici 23 plan s tipičnim grobovima četiriju kronoloških faza u tumulu 48. Četvrtoj fazi koja bi trebala odgovarati certoškom stupnju doljenjske halštatske skupine, pripisao je samo dvanaest grobova, koji su svi osim jednoga pripadali ženama. Međutim, četiri od tih grobova zapravo su stariji. S druge strane, barem dvadeset osam drugih grobova certoškoga stupnja u tumulu 48, kako ženskih tako i muških, trebalo bi pridodati broju od osam ispravno datiranih grobova četvrte faze. Neki od tih grobova vrlo su bogati te pružaju velike mogućnosti za novu tipološku i kronološku analizu ovoga stupnja.*

*Ključne riječi: Slovenija, Stična, starije željezno doba, tumul 48, halštatska kultura, doljenjska skupina, kronologija, certoški stupanj*

In the last 12 years two volumes on the Early Iron Age tumuli from Stična in the Dolenjska region were edited by the National Museum of Slovenia, the first being *Stična II/1, Katalog (Catalogue)* in 2006 (Gabrovec 2006), followed by *Stična II/2, Razprave (Studies)* in 2010 (Gabrovec, Teržan 2010). Since the primary authors are Prof. Stane Gabrovec, who regretfully died at a great age in January 2015, and Prof. Biba Teržan, both publications were expected to be of very high quality. A thorough review of these volumes, however, has demonstrated that they are a disappointment, the second one to a much greater extent.

### THE FOURTH CHRONOLOGICAL PHASE OF BARROW 48

The aim of this study is to reconsider Gabrovec's presentation of the final and fourth chronological phase, of barrow 48 in his chapter *Gomila 48 / Grabhügel 48* in volume *Stična II/2* (Gabrovec 2010: 36–60).

Gabrovec assigned the complete graves, incomple-

U posljednjih dvanaest godina Narodni muzej Slovenije objavio je dva sveska posvećena stariježeljeznodobnim tumulima iz Stične u Dolenjskoj: 2006. godine izašla je *Stična II/1, Katalog* (Gabrovec 2006), nakon čega je 2010. godine uslijedila *Stična II/2, Razprave* (Gabrovec, Teržan 2010). S obzirom na to da su glavni autori ovih publikacija prof. Stane Gabrovec koji nas je nažalost napustio u visokoj dobi u siječnju 2015. godine, te prof. Biba Teržan, za obje se publikacije očekivalo da će biti vrlo visoke kvalitete. Međutim, podrobna je analiza pokazala da je zapravo riječ o razočaranjima, pri čemu se to znatno više odnosi na drugu publikaciju.

### ČETVRTA KRONOLOŠKA FAZA TUMULA 48

Cilj je ovog rada ponuditi osvrt na Gabrovecovu prezentaciju četvrte i završne kronološke faze tumula 48 u poglavlju *Gomila 48 / Grabhügel 48* u publikaciji *Stična II/2* (Gabrovec 2010: 36–60).

Cjelovite grobove, necjelovite grobove, kao i takozvane

te graves, and so-called finds of barrow 48, a total of 181 units all together (Gabrovec 2010: 16), to four stratigraphic and chronological phases. In the last phase the barrow was widened to a diameter of 46.30 m, made taller, and surrounded by a stone ring. The graves of this phase, 97 in total, were dug in the body of the barrow (Gabrovec 2010: 39: *Von da an bestattete man die Verstorbenen im Mantel des Grabhügels. Die Zahl dieser Gräber beträgt 97; 44: Von da an errichtete man Gräber nur noch in der Aufschüttung des Grabhügels. Von diesen gibt es 97 Bestattungen.* and ...und die vierte Phase 97 Gräber in der Aufschüttung des Grabhügels).

At the beginning of the subchapter "Chronology," Gabrovec again quotes the number of graves attributed to the fourth chronological phase, but here the number is surprisingly reduced from 97 graves to only 10! (Gabrovec 2010: 47: *Mit Beginn der letzten Belegungsphase begrub man die Verstorbenen vor allem im Mantel des Grabhügels. Davon gibt es 10 Gräber. Es handelt sich um die Bestattungen der vierten chronologischen Stufe.*). The numbers of these ten graves appear in Figure 21 on page 40: 8, 36, 44, 48, 50, 67, 103, 119–120, 169, and 171 (Fig. 1). On the ground plan of barrow 48 in Figure 23 on page 50 (Fig. 2), the graves of the fourth phase are coloured with yellow. Here, however, instead of graves 67 and 171 two other graves are designated as fourth phase, graves 98 and 104!

Gabrovec writes about the fourth phase again in the second paragraph on page 55. First he mentions the fibulae that appear in graves from this phase: serpentine fibulae (in 10 graves), Certosa fibulae (in nine graves – in fact only in seven: 8, 25, 49, 54, 58, 99, and 121), animal-shaped fibulae (in 2 graves), and a three-knobbed fibula (in 1 grave). Altogether, 19 graves have fibulae (grave 121 contained three Certosa fibulae and a three-knobbed fibula). Surprisingly, he does not mention the associated grave numbers. He continues with bracelets and says that there are some new types (*Neu sind folgende Armringtypen*): hollow in graves 8, 119–120, and 169, and deeply ribbed ones with touching ends in graves 8, 67, and 103. He has forgotten that the latter form also appeared in two graves that he assigned to the third chronological phase (29 and 85 – Gabrovec 2010: 54). The most frequent type in the fourth phase would be bracelets with small or somewhat larger ribs, which appear in six graves. He did not say that they had overlapping ends, if better preserved, or that this form is not new at all, but was even better represented in the preceding third phase

nalaze iz tumula 48, sveukupno 181 cjelinu (Gabrovec 2010: 16), Gabrovec je pripisao četirima stratigrafskim i kronološkim fazama. U posljednjoj fazi tumul je proširen tako da mu je promjer zahvaćao 46,30 m, povišen je te je obrubljen s kamenim vijencem. Grobovi ove faze, njih ukupno 97, ukopani su u nasipu tumula (Gabrovec 2010: 39: *Von da an bestattete man die Verstorbenen im Mantel des Grabhügels. Die Zahl dieser Gräber beträgt 97; 44: Von da an errichtete man Gräber nur noch in der Aufschüttung des Grabhügels. Von diesen gibt es 97 Bestattungen, i ... und die vierte Phase 97 Gräber in der Aufschüttung des Grabhügels*).

Na početku potpoglavlja *Kronologija* Gabrovec je ponovno naveo broj grobova koje je pripisao četvrtoj kronološkoj fazi, no na ovom je mjestu broj iznenađujuće snižen s 97 na tek 10! (Gabrovec 2010: 47: *Mit Beginn der letzten Belegungsphase begrub man die Verstorbenen vor allem im Mantel des Grabhügels. Davon gibt es 10 Gräber. Es handelt sich um die Bestattungen der vierten chronologischen Stufe.*). Redni brojevi tih deset grobova pojavljuju se na slici 21 na stranici 40: 8, 36, 44, 48, 50, 67, 103, 119–120, 169 i 171 (sl. 1). Na tlocrtu tumula 48 na slici 23 na stranici 50 (sl. 2) grobovi četvrte faze označeni su žutom bojom. Međutim, umjesto grobova 67 i 171, ovdje su druga dva groba pripisana četvrtoj fazi, naime, grobovi 98 i 104!

Gabrovec se ponovno bavi četvrtom fazom u drugom odlomku na stranici 55. Prvo spominje fibule koje se pojavljuju u grobovima te faze: zmijolike fibule (u deset grobova), certoške fibule (u devet grobova – zapravo u sedam: 8, 25, 49, 54, 58, 99 i 121), zoomorfne fibule (2 groba) te fibula s tri dugmeta na luku (1 grob). Sve u svemu, 19 grobova sadržavalo je fibule (grob 121 imao je tri certoške fibule i fibulu s tri dugmeta na luku). Iznenađujuće, ne spominje pripadajuće brojeve grobova. Zatim nastavlja s narukvicama, spominjući kako se pojavljuju neki novi tipovi (*Neu sind folgende Armringtypen*): šuplje narukvice u grobovima 8, 119–120 i 169 te duboko narebrene narukvice s krajevima koji se dodiruju, u grobovima 8, 67 i 103. Zaboravio je da se posljednji oblik pojavljuje također i u dva groba koja je pripisao trećoj kronološkoj fazi (29 i 85 – Gabrovec 2010: 54). Najčešći tip u četvrtoj fazi bile bi narukvice s malim ili nešto većim rebri-ma, koje se pojavljuju u šest grobova. Nije spomenuo da im se krajevi preklapaju, ako su bolje sačuvani, ni da ovo uopće

	Graves / Grobovi
Phase / faza I	19-22, 100, 101
Phase / faza II	2, 6, 27, 41, 72, 80, 87-87a, 127, 131, 132, 134, 136, 147, 150, 151, 152, 154, 156, 157, 158, 167, 174, 175
Phase / faza III	29, 30, 74, 81, 85, 97, 99, 110, 112, 129, 130, 138, 165, 172, 179
Phase / faza IV	8, 36, 44, 48, 50, 67, 103, 119-120, 169, 171

Fig. 1 Gabrovec's table with typical graves from the four chronological phases of barrow 48 at Stična (Gabrovec 2010: 40, Fig. 21). Red numbers designate graves which in fact belong to the Stična 2 phase, green numbers those from the Serpentine Fibulae phase, and orange numbers those from the Certosa phase

Sl. 1 Gabrovecova tablica tipičnih grobova četiriju kronoloških faza tumula 48 u Stični (Gabrovec 2010: 40, sl. 21). Crveni brojevi označavaju grobove, koji zapravo pripadaju stupnju Stična 2, zeleni grobove stupnja zmijolike fibule, dok narančasti označavaju grobove certoškoga stupnja

(*In der dritten chronologischen Stufe...Mit 20 Exemplaren am zahlreichsten sind die fein gerippten Ringe mit überlappenden Enden in zehn Gräbern.*). He also did not note six graves, but only five: 36, 44, 48, 50 and 171.

These ten graves with different types of bracelets (8, 36, 44, 48, 50, 67, 103, 119–120, 169, and 171) are the same ten graves that were assigned to the fourth phase in the table in Figure 21 (here Fig. 1), presenting typical graves from the four phases. This discrepancy between the text and the table means that he omitted almost all of the graves with fibulae, assigned by him in the text to the fourth phase, and which in his opinion would be 21, from this table. Only grave 8 from the aforementioned ten graves contains three fibulae in addition to the bracelets and anklets, while in grave 36, three fragments of a boat fibula were found in addition to two earrings and two bracelets (Gabrovec 2006: Pl. 3–4; 42–43, Grave 36, No. 4, Pl. 27: 36). On the other hand, he wrongly assigned a large number of graves to this phase in his text, which are in reality earlier! Seven of them contain serpentine fibulae of types IV, V, and VI following Tecco Hvala (Tecco Hvala 2014: 168–170, Fig. 4–6), and their numbers were not specified by him, and four (36, 44, 48, and 171) contain ribbed bracelets with tapered overlapping ends. They must all be dated without any doubt to the preceding Serpentine Fibulae phase (Gabrovec 1987: 58–59, Fig. 4: 6, 10, 12–13), one of them (36) because of the fragments of a boat fibula even to the transition between the Stična 2 and the Serpentine Fibulae phases. Only three, not ten graves in barrow 48 with serpentine fibulae can be assigned to the Certosa phase: grave 76 with a pair of serpentine fibulae of type IIIa7 following Tecco Hvala (Gabrovec 2006: Pl. 44; Tecco Hvala 2014: 129, 168, Fig. 3a; 9) as well as graves 34 and 54 with serpentine fibulae of type VIIc following Tecco Hvala (Gabrovec 2006: Pl. 27: 34/1; Pl. 34: 54/1–2; Tecco Hvala 2014: 138, 171, Fig. 7; 9). What confusion!

## WHAT WENT WRONG?

In 2010 Gabrovec was 90 years old. It was the duty of Biba Teržan, the main co-author, the two reviewers Janez Dular and Mitja Guštin, all three his former students, and also of Peter Turku, a student of Teržan and the editor-in-chief and managing editor of the series *Katalogi in monografije*, in which *Stična II/2* is included, to thoroughly read Gabrovec's text, to check the contents of the figures, and to propose necessary emendations.

Judging by the printed subchapter "Chronology" they did not read or check Gabrovec's text and figures thoroughly enough. It should also be mentioned that the other three members of the editorial committee of *Katalogi in monografije*, Janka Istenič and Timotej Knific of the National Museum of Slovenia and myself, did not have any oversight in the preparation of either *Stična* volume, *Stična II/1* or *II/2*. We only saw them after their release.

In the last paragraph of Gabrovec's Chronology subchapter, on page 56, Gabrovec writes that the four stratigraphic and chronological phases of barrow 48 present many new aspects and that they do not harmonize completely with his chronology of the Hallstatt period in Dolenjska,

nije novi oblik, nego je zapravo čak i bolje zastupljen u prethodnoj, trećoj fazi (*In der dritten chronologischen Stufe ... Mit 20 Exemplaren am zahlreichsten sind die fein gerippten Ringe mit überlappenden Enden in zehn Gräbern.*). K tomu, nije ni naveo šest nego tek pet grobova: 36, 44, 48, 50 i 171.

Ovih deset grobova s različitim tipovima narukvica (8, 36, 44, 48, 50, 67, 103, 119–120, 169 i 171) istih je deset grobova pripisanih četvrtoj fazi u tablici na slici 21 (ovdje sl. 1), koja predstavlja tipične grobove četiriju faza. Ovaj raskorak između teksta i tablice znači da je iz tablice izostavio gotovo sve grobove s fibulama koje je u tekstu pripisao četvrtoj fazi, a kojih bi prema njegovu mišljenju bilo 21. Jedino grob 8 od spomenutih deset grobova sadrži tri fibule, uz narukvice i nanogvice, dok su u grobu 36 tri ulomka čunjaste fibule nađena zajedno s dvije naušnice i dvije narukvice (Gabrovec 2006: T. 3–4, 42–43, grob 36, br. 4, T. 27: 36). S druge strane, pogrešno je u svom tekstu pripisao ovoj fazi velik broj grobova, dok su oni zapravo stariji! Sedam od tih grobova sadrži zmijolike fibule tipa IV, V i VI prema Tecco Hvala (Tecco Hvala 2014: 168–170, sl. 4–6), a njihove brojeve nije naveo, dok četiri (36, 44, 48 i 171) sadrže narebrene narukvice sa suženim prebačenim krajevima. Svi se ti grobovi bez ikakve sumnje moraju datirati u prethodni stupanj zmijolike fibule (Gabrovec 1987: 58–59, sl. 4: 6, 10, 12–13), a jedan od njih (36) zbog ulomaka čunjaste fibule čak i ranije, na prijelaz stupnja Stična 2 na stupanj zmijolike fibule. Samo tri, a ne deset grobova u tumulu 48 sa zmijolikim fibulama mogu se pripisati certoškom stupnju: grob 76 s parom zmijolikih fibula tipa IIIa7 prema Tecco Hvala (Gabrovec 2006: T. 44; Tecco Hvala 2014: 129, 168, sl. 3a; 9), kao i grobovi 34 i 54 sa zmijolikim fibulama tipa VIIc prema Tecco Hvala (Gabrovec 2006: T. 27: 34/1; T. 34: 54/1–2; Tecco Hvala 2014: 138, 171, sl. 7; 9). Kakva zbrka!

## ŠTO SE DOGODILO?

Gabrovec je 2010. godine navršio devedesetu. Na njegovim bivšim studentima Bibi Teržan, kao glavnom koautoru, kao i dva recenzenta, Janezu Dularu i Mitji Guštinu, a k tomu i na Peteru Turku, studentu B. Teržan te glavnom i odgovornom uredniku serije *Katalogi i monografije*, unutar koje je publicirana *Stična II/2*, ležala je odgovornost da temeljito iščitaju Gabrovčev tekst, provjere sadržaj ilustracija te da predlože neophodna poboljšanja.

Sudeći prema potpoglavlju *Kronologija*, oni nisu pročitali ili provjerili Gabrovčev tekst i ilustracije dovoljno temeljito. Također treba napomenuti da preostala tri člana uredničkog odbora *Kataloga i monografija*, Janka Istenič i Timotej Knific iz Narodnog muzeja Slovenije te autor ovog prikaza, nisu imala uvid u pripremu ni prvog ni drugog sveska *Stične* (II/1 i II/2). Vidjeli smo ih tek nakon što su objavljeni.

U posljednjem odlomku svoga potpoglavlja o *Kronologiji*, na stranici 56, Gabrovec piše kako četiri stratigrafske i kronološke faze tumula 48 donose brojne nove aspekte, kao i to da nisu u potpunom skladu s njegovom kronologijom halštatskog razdoblja u Dolenjskoj, koju je posljednji



which he last comprehensively defined in 1987 in volume 5 of *Praistorija jugoslavenskih zemalja* devoted to the Iron Age (Gabrovec 1987: 35–79).

### DIFFERENT CHRONOLOGIES

In reality this chronology, published 29 years ago, remains the most accurate, comprehensive, well organized, and well explained version, even now, but unfortunately it was only published in Croato-Serbian. It should be translated into English and put on the internet with necessary comments in the near future. In 2003 Janez Dular published a “new” chronology in his book *Halštatske nekropole Dolenjske* that was presented bilingually in Slovenian and in German, but it is more or less only a short summary of Gabrovec’s 1987 chronology (Dular 2003: 99–150; cf. Teržan 2010: 276, n. 207). The chronological table on page 293 of the 2010 *Stična II/2* monograph, prepared by Biba Teržan, contains only a small number of warrior graves from some of the barrows at Stična. It does not deserve any designation except as “a mostly wrong chronology.” Teržan, for example, was the first to divide the Serpentine Fibulae phase into subphases 1 and 2 (Kačaste fibule 1 and 2), which in reality cannot be done. She dated grave 48/33 to the beginning of this phase, grave 48/76 to subphase 1 and grave 48/49 to subphase 2. All three graves in reality must be dated to the Certosa phase!

Finally, four years ago (2012), Sneža Tecco Hvala, a student of Teržan, published a table on page 346 of her book on the Magdalenska gora Hallstatt graves (Tecco Hvala 2012), edited by the Institute of Archaeology in Ljubljana, where she assigned a large number of graves from Magdalenska gora to all phases of the Hallstatt period from the Podzemelj 1 phase to the Negova helmets 2 phase. She not only included many graves from the Mecklenburg Collection in the table, which are mixed and completely unreliable (Božič 2009; 2010), but also wrongly dated several more or less reliable graves that were excavated at Magdalenska gora for the Natural History Museum in Vienna.

### GABROVEC’S FOUR PHASES

Let me return to Gabrovec’s subchapter *Kronologija / Chronologie* in the *Stična II/2* monograph (Gabrovec 2010: 46–56). In the table with typical graves for the four chronological phases (Fig. 21 on p. 40 – here Fig. 1) Gabrovec assigned graves 100, 101 and 19–22 to the first phase, corresponding to the Podzemelj phase of the Dolenjska group. The last grave, the so called central grave of barrow 48, was according to Teržan a wooden chamber, around 8 m long, around 5.5 m wide and around 3.5 m high, which was surrounded and covered by stone slabs (Teržan 2010: 192–193). Although several much smaller wooden chambers were relatively well preserved in barrow 48 (Gabrovec 2010: 43), practically no remains have been reported from the largest one. From the large quantity of stone slabs necessary to surround and cover such a huge chamber, a surprisingly small amount was found, in any case not at all around the supposed huge rectangular wooden chamber, which disappeared without any trace!

put sveobuhvatno definirao 1987. godine u petom svesku *Praistorije jugoslavenskih zemalja*, posvećenom željeznom dobu (Gabrovec 1987: 35–79).

### RAZLIČITE KRONOLOGIJE

U stvarnosti je ova kronologija, objavljena prije 29 godina, do današnjeg dana ostala najpreciznija verzija, sveobuhvatna, dobro organizirana i dobro objašnjena. Međutim, nažalost, objavljena je samo na hrvatsko-srpskom jeziku. Trebalo bi je u najskorije vrijeme prevesti na engleski jezik i staviti na internet, zajedno s neophodnim komentarima. Janez Dular objavio je 2003. godine „novu” kronologiju u svojoj knjizi *Halštatske nekropole Dolenjske*, objavljenoj dvojezično, na slovenskom i njemačkom, no više ili manje je riječ tek o kratkom sažetku Gabrovčeve kronologije iz 1987. godine (Dular 2003: 99–150; cf. Teržan 2010: 276, nap. 207). Kronološka tablica na 293. stranici monografije *Stična II/2* iz 2010., koju je priredila Biba Teržan, sadrži tek manji broj ratničkih grobova iz nekih od tumula iz Stične. Ne zavrđuje da ju se posebno odredi osim kao „uglavnom pogrešnu kronologiju”. Teržan je, primjerice, prva podijelila stupanj zmijolike fibule na podstupnjeve 1 i 2 (Kačaste fibule 1 i 2), što se zapravo ne može učiniti. Datirala je grob 48/33 na početak ovog stupnja, grob 48/76 u podstupanj 1 te grob 48/49 u podstupanj 2. Zapravo se sva tri groba moraju datirati u certoški stupanj!

Napokon, prije četiri godine (2012.), Sneža Tecco Hvala, studentica B. Teržan, objavila je tablicu na stranici 346 svoje knjige o halštatskim grobovima na Magdalenskoj gori (Tecco Hvala 2012), koju je objavio ljubljanski Institut za arheologiju, u kojoj je velik broj grobova s Magdalenske gore pripisala svim stupnjevima halštatskog razdoblja od stupnja Podzemelj 1 do negovskog stupnja 2. Ne samo da je u tablicu uključila brojne grobove iz zbirke Mecklenburg, koji su pomiješani i potpuno nepouzdana (Božič 2009; 2010), nego je k tomu i pogrešno datirala nekoliko više ili manje pouzdanih grobova koji su na Magdalenskoj gori iskopani za bečki Prirodoslovni muzej.

### GABROVČEVE ČETIRI FAZE

Vratimo se sada Gabrovčevu potpoglavlju *Kronologija / Chronologie* u monografiji *Stična II/2* (Gabrovec 2010: 46–56). U tablici s tipičnim grobovima za četiri kronološke faze (sl. 21 na str. 40 – ovdje sl. 1) Gabrovec je grobove 100, 101 te 19–22 pripisao prvoj fazi, koja odgovara stupnju Podzemelj dolenske grupe. Posljednji grob, takozvani središnji grob tumula 48, prema Teržan se sastojao od drvene komore duge oko 8 m, široke oko 5,5 m te visoke oko 3,5 m, okružene i pokrivene kamenim pločama (Teržan 2010: 192–193). Iako je tumul 48 sadržavao nekoliko razmjerno dobro očuvanih, znatno manjih drvenih komora (Gabrovec 2010: 43), u slučaju najveće komore zapravo nije izviješteno o nikakvim ostacima. I od velike količine kamenih ploča neophodnih da se okruži i prekrije tako golema komora, pronađena je izne-

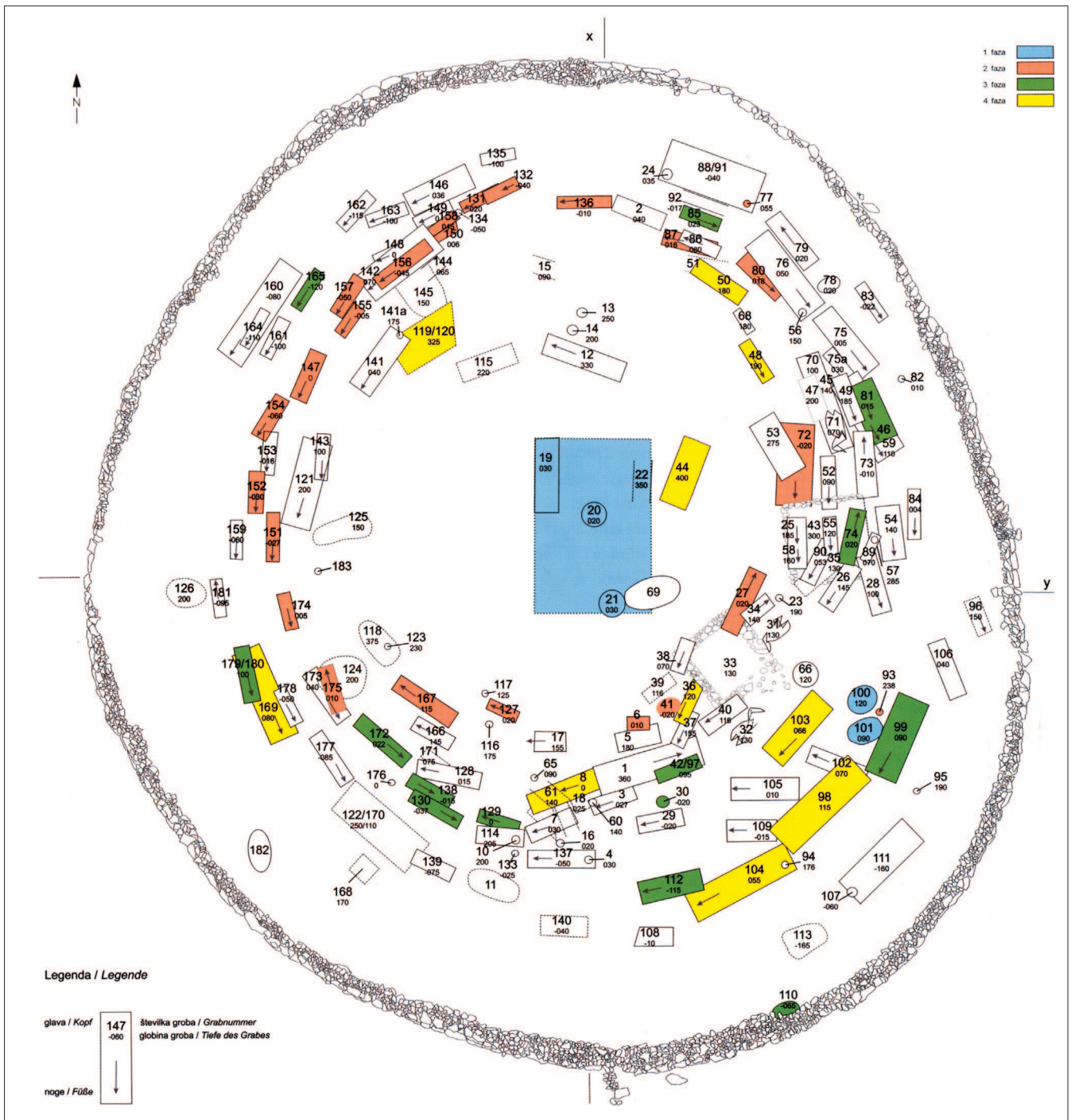

Fig. 2 Ground plan of barrow 48 at Stična with typical graves of four chronological phases (Gabrovec 2010: 50). The supposed graves of the 4th phase are coloured yellow

Sl. 2 Tlocrt tumula 48 u Stični s tipičnim grobovima četiriju kronoloških faza (Gabrovec 2010: 50). Pretpostavljeni grobovi 4. faze označeni su žutom bojom

This central grave, dated to the Podzemelj phase by Gabrovec and Teržan (2010: 47, 276–277), is a pure invention of Biba Teržan. I shall write more exhaustively about it in some other paper (cf. nevertheless Božić 2015: 142, 148). Let me write just one remark here. The footed vases from finds 20 and 21 (Gabrovec 2006: Pl. 10), assigned to the central grave “from the Podzemelj phase,” cannot be earlier than from the Stična 2 phase. First because of the red and black decoration, which was definitely not in use before the Stič-

nađuće mala količina, u svakom slučaju ne oko navodno goleme drvene komore, koja je nestala bez traga!

Ovaj središnji grob koji su Gabrovec i Teržan (2010: 47, 276–277) datirali u stupanj Podzemelj, potpuna je izmišljotina Bibe Teržan. O tome ću mnogo opširnije pisati u nekom drugom radu (vidjeti ipak Božić 2015: 142, 148). Ovdje ću ipak iznijeti još jednu opasku. Ciboriji iz nalaza 20 i 21 (Gabrovec 2006: T. 10), pripisanih središnjem grobu „iz stupnja Podzemelj”, ne mogu biti raniji od stupnja Stična 2. Prije

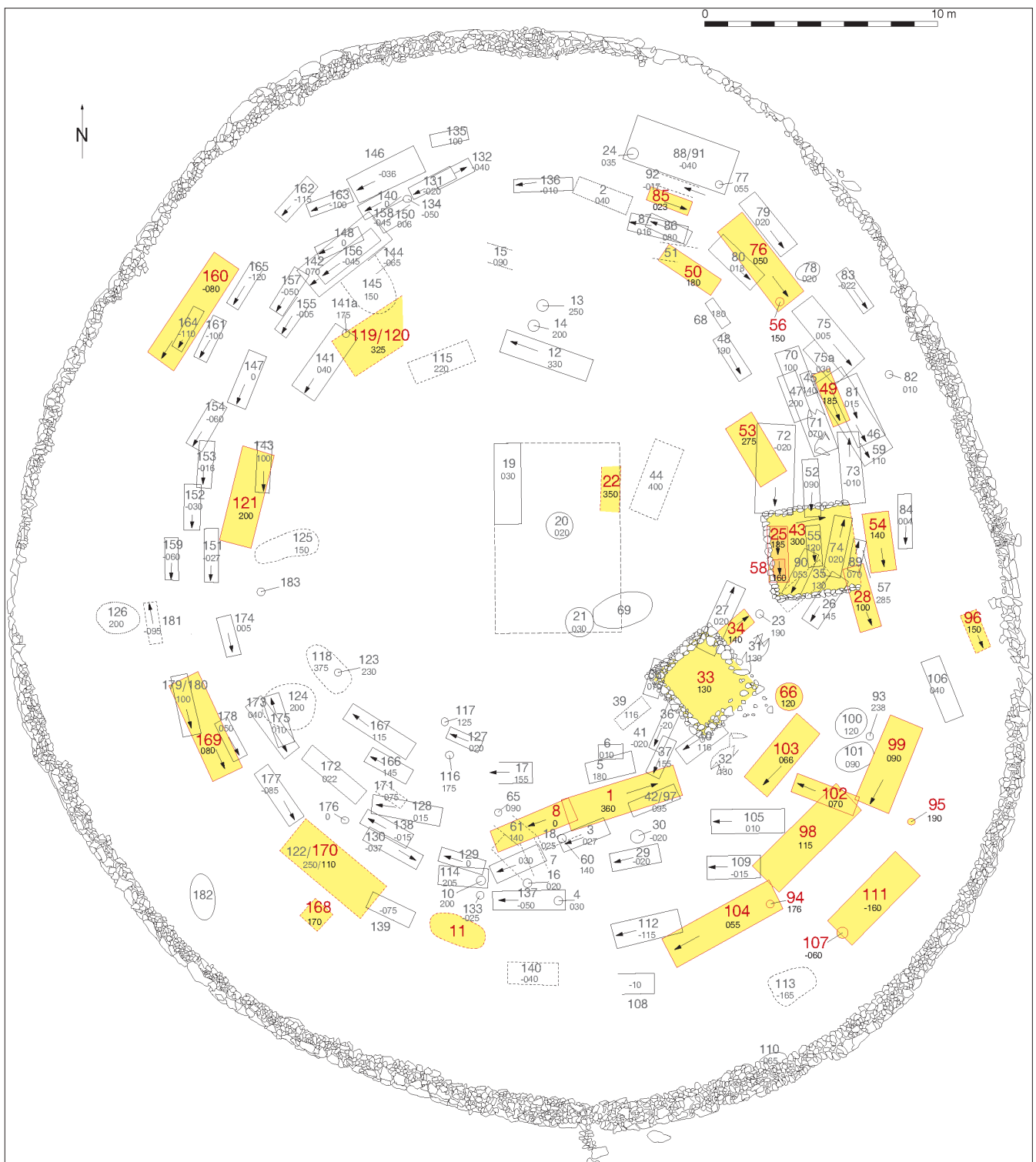

Fig. 3 Ground plan of barrow 48 at Stična with graves from the Certosa phase, coloured yellow  
 Sl. 3 Tlocrt tumula 48 u Stični s grobovima certoške faze, označenim žutom bojom

na 2 phase, and which only appeared rarely in this phase and became popular only in the Serpentine Fibulae phase (Dular 1982: 91). Second because their feet are decorated with horizontal grooves, a typical decoration of the footed vases of type 8 following Dular (Dular 1982: 49–50, 185, Pl. 15), which often appear in graves of the Stična 2 phase of barrow 48 (Gabrovec 2006: Pl. 10, 23, 36, 40), in one case (grave 167) even in a grave, dated to the transition from the

svega zbog crvenog i crnog ukrasa koji se definitivno nije koristio prije stupnja Stična 2 te koji se u ovoj fazi pojavljivao tek rijetko, postavši popularan tek u stupnju zmijolike fibule (Dular 1982: 91). Drugo, njihove su noge ukrašene vodoravnim žljebovima, što je tipičan ukras ciborija tipa 8 prema Dularu (Dular 1982: 49–50, 185, T. 15), koji se često pojavljuju u grobovima stupnja Stična 2 u tumulu 48 (Gabrovec 2006: T. 10, 23, 36, 40), a u jednom slučaju (grob 167) čak i u grobu

Stična 2 phase to the Serpentine Fibulae phase (Gabrovec 2006: Pl. 96).

Gabrovec assigned 23 graves to his second phase. In reality only 10 of them belong to the Stična 2 phase (graves 2, 27, 41, 72, 80, 87–87a, 127, 132, 134 and 156 – cf. Gabrovec 1987: 42–55, Fig. 2–3), the other not. Eight belong to the Serpentine Fibulae phase (graves 131, 136, 147, 151, 152, 154, 174 and 175 – Gabrovec 1987: 55–60, Fig. 4) and 2 to the transition from the Stična 2 phase to the Serpentine Fibulae phase (graves 157 and 167). To this transition can be dated also grave 153, not included in the Gabrovec's table.

Most of the fifteen graves that Gabrovec assigned to the third phase really belong to the Serpentine Fibulae phase (10: graves 30, 81, 97, 110, 112, 129, 138, 165, 172 and 179). One grave (74), however, belongs to the Stična 2 phase, one (29) to the transition from the Serpentine Fibulae phase to the Certosa phase and two undoubtedly to the Certosa phase (graves 85 and 99 – Gabrovec 1987: 60–69, Fig. 5).

Similarly, eight of the twelve graves from Gabrovec's fourth phase (ten assigned to this phase on Fig. 21 and two other, graves 98 and 104, on Fig. 23; all but one are unexpectedly female) can really be placed into the Certosa phase (8, 50, 67, 98, 103, 104, 119–120 and 169), while three of them belong to the preceding Serpentine Fibulae phase (44, 48 and 171). Grave 36 belongs, as already mentioned, to the transition from the Stična 2 to the Serpentine Fibulae phase.

It is clear that the four phases as defined by Gabrovec are not chronological phases at all. It is also clear that the earliest graves in barrow 48 at Stična are no earlier than the Stična 2 phase and that at the final extent are no later than the second part of the Certosa phase. Since the emphasis of this study is on Gabrovec's fourth phase, I shall name below all those graves that can be assigned to the Certosa phase with certainty and that are mostly missing or were even wrongly attributed to the third and first phase in Figure 21 (here Fig. 1).

#### **THE TYPES OF FINDS BELONGING TO THE FOURTH PHASE OF BARROW 48 THAT CORRESPONDS TO THE CERTOSA PHASE OF THE DOLENJSKA HALLSTATT GROUP**

The graves of the Certosa phase in barrow 48 are easily recognizable. With very few exceptions they contain new types of artifacts, unknown in the preceding phases (Pl. 1–4):

Type 1: Certosa fibulae of type II following Teržan (e.g. Gabrovec 2006: Pl. 3: 1, 3; Pl. 14: 25/1–2 – Teržan 1976);

Type 2: Certosa fibulae of type V following Teržan (e.g. Pl. 56: 1–2; 71: 1–3);

Type 3: Certosa fibulae of type XIII following Teržan (Pl. 35: 58/1; Pl. 105: 1962/1–2);

Type 4: a three-knobbed fibula of type VII following Ogrin (Pl. 71: 4 – Ogrin 1998);

Type 5: a triga-shaped fibula (Pl. 5: 9/1);

datiranom na prijelaz stupnja Stična 2 na stupanj zmijolike fibule (Gabrovec 2006: T. 96).

Gabrovec je svojoj drugoj fazi pripisao 23 groba. Zapravo tek deset od tih grobova pripada stupnju Stična 2 (grobovi 2, 27, 41, 72, 80, 87–87a, 127, 132, 134 i 156 – cf. Gabrovec 1987: 42–55, sl. 2–3), a ostali ne. Osam ih pripada stupnju zmijolike fibule (grobovi 131, 136, 147, 151, 152, 154, 174 i 175 – Gabrovec 1987: 55–60, sl. 4), a dva pripadaju prijelazu stupnja Stična 2 na stupanj zmijolike fibule (grobovi 157 i 167). Na ovaj se prijelaz može datirati i grob 153, koji nije uključen u Gabrovčevu tablicu.

Većina od petnaest grobova koje je Gabrovec pripisao trećoj fazi uistinu pripada stupnju zmijolike fibule (10: grobovi 30, 81, 97, 110, 112, 129, 138, 165, 172 i 179). Jedan grob (74), međutim, pripada stupnju Stična 2, jedan (29) spada u prijelaz iz stupnja zmijolike fibule u certoški stupanj, dok dva nesumnjivo pripadaju certoškom stupnju (grobovi 85 i 99 – Gabrovec 1987: 60–69, sl. 5).

Slično tomu, osam od dvanaest grobova Gabrovčeve četvrte faze (deset pripisanih ovoj fazi na sl. 21 i dva druga, grobovi 98 i 104, na sl. 23; svi su osim jednoga, neočekivano, ženski) zaista se mogu smjestiti u certoški stupanj (8, 50, 67, 98, 103, 104, 119–120 i 169), dok tri pripadaju prethodnom stupnju zmijolike fibule (44, 48 i 171). Grob 36, kao što je već spomenuto, pripada prijelaznom stupnju iz Stične 2 u stupanj zmijolike fibule.

Jasno je da četiri faze kako ih je odredio Gabrovec zapravo uopće nisu kronološke faze. Također je jasno da najraniji grobovi u tumulu 48 iz Stične nisu raniji od stupnja Stična 2 te da u konačnici nisu kasniji od drugog dijela certoškoga stupnja. S obzirom na to da smo u ovom radu stavili naglasak na Gabrovčevu četvrtu fazu, u nastavku ću navesti sve one grobove koji se sa sigurnošću mogu pripisati certoškom stupnju, a koji su uglavnom izostavljeni ili su čak pogrešno atribuirani trećoj i prvoj fazi na slici 21 (ovdje sl. 1).

#### **TIPOVI NALAZA KOJI PRIPADAJU ČETVRTOJ FAZI TUMULA 48, KOJA ODGOVARA CERTOŠKOM STUPNJU DOLENJSKE HALŠTATSKE SKUPINE**

Grobovi certoškoga stupnja u tumulu 48 mogu se lako raspoznati. Uz tek nekoliko iznimaka, sadrže nove tipove predmeta, nepoznate u prethodnim fazama (T. 1–4):

Tip 1: certoške fibule tipa II prema Teržan (npr. Gabrovec 2006: T. 3: 1, 3; 14: 25/1–2 – Teržan 1976);

Tip 2: certoške fibule tipa V prema Teržan (npr. T. 56: 1–2; 71: 1–3);

Tip 3: certoške fibule tipa XIII prema Teržan (T. 35: 58/1; T. 105: 1962/1–2);

Tip 4: fibula s tri dugmeta na luku tipa VII prema Ogrin (T. 71: 4 – Ogrin 1998);

- Type 6: a fibula with a bow in the shape of a dog (Pl. 60: 102/1);
- Type 7: Serpentine fibulae of type IIIa7 following Tecco Hvala (Pl. 44: 1–2 – Tecco Hvala 2014);
- Type 8: Serpentine fibulae of type VIIc following Tecco Hvala (Pl. 27: 34/1; 34: 54/1–2);
- Type 9: an early Negova helmet (Pl. 62: 1);
- Type 10: spearheads with a faceted socket (Pl. 26: 16);
- Type 11: an iron sheath for spearheads (Pl. 26: 16);
- Type 12: bronze trilobate arrowheads (Pl. 23: 28/1–2; 26: 17);
- Type 13: a bronze rectangular belt plate, decorated in the situla style (Pl. 62: 2);
- Type 14: strap-shaped belt attachments with rings (e.g. Pl. 14: 25/4–9; 34: 54/7–11);
- Type 15: horse bits of the Szentes-Vekerzug type (Pl. 32: 49/6; 57: 16);
- Type 16: strap dividers with horse-head protomes (Pl. 57: 10–13);
- Type 17: disk-shaped strap dividers with two loops on the back (Pl. 23: 28/3; 64: 111/2–3);
- Type 18: a bronze mace with a partly polygonal shaft cross-section (Pl. 25: 33/1);
- Type 19: hollow bronze bracelets and anklets (e.g. Pl. 97: 1–2; 68);
- Type 20: thick ribbed solid bronze bracelets and anklets with touching ends (e. g. Pl. 24: 1–2; 4: 11–12);
- Type 21: glass beads with layered eyes (e.g. Pl. 1: 15; 5: 9/9);
- Type 22: vase-shaped glass beads (e.g. Pl. 55: 98/5–6; 69: 15–21);
- Type 23: barrel-shaped glass beads with collars at the ends and four knobs in the middle (Pl. 3: 8);
- Type 24: a screw-shaped glass bead (Pl. 71: 14);
- Type 25: a spindlewhorl-shaped glass bead (Pl. 55: 98/4);
- Type 26: extremely large flattened globular amber beads (Pl. 35: 67/2; 91: 9);
- Type 27: disk-shaped amber beads, decorated with incisions (e.g. Pl. 1: 16; 55: 98/18);
- Type 28: amber beads with additional vertical or oblique perforations (Pl. 1: 18; 33: 53/1–2; 55: 98/16);
- Type 29: amber bulla-shaped pendants (Pl. 1: 17; 55: 98/17);
- Type 30: amber spacer plates (Pl. 69: 23; 92: 160/15);
- Type 31: a dish with indented walls of type 5 following Dular (Pl. 35: 66/1 – Dular 1982: 195, Pl. 24: 226–232);
- Type 32: footed vases of type 10 following Dular (Pl. 14: 25/14; 33: 50/4; 44: 18 – Dular 1982: 185, Pl. 17);
- Type 33: a footed vase of type 11 following Dular (Pl. 50: 12 – Dular 1982: 185, Pl. 18: 154–156);
- Type 34: a cup with two animal heads on the handle of type 5 following Dular (Pl. 62: 8 – Dular 1982: 192, Pl. 22: 197–202);
- Type 35: footed dishes with indented walls of type 2 following Dular (e.g. Pl. 33: 50/6; 34: 54/16 – Dular 1982: 196, Pl. 25: 236–243);
- Type 36: a large cordoned bronze cist with two side handles (Pl. 44: 13).
- Tip 5: fibula u obliku trige (T. 5: 9/1);
- Tip 6: fibula s lukom u obliku psa (T. 60: 102/1);
- Tip 7: zmijolika fibula tipa IIIa7 prema Tecco Hvala (T. 44: 1–2 – Tecco Hvala 2014);
- Tip 8: zmijolika fibula tipa VIIc prema Tecco Hvala (T. 27: 34/1; 34: 54/1–2);
- Tip 9: rana negovska kaciga (T. 62: 1);
- Tip 10: koplja s fasetiranim tuljcem (T. 26: 16);
- Tip 11: željezne korice za koplja (T. 26: 16);
- Tip 12: trobridne brončane strelice (T. 23: 28/1–2; 26: 17);
- Tip 13: brončana pravokutna pojasna kopča, ukrašena u situlskom stilu (T. 62: 2);
- Tip 14: trakasti pojasni okovi s obručima (npr. T. 14: 25/4–9; 34: 54/7–11);
- Tip 15: konjske žvale tipa Szentes-Vekerzug (T. 32: 49/6; 57: 16);
- Tip 16: razvodnici remenja s konjskim protomama (T. 57: 10–13);
- Tip 17: diskoidni razvodnici remenja s dvije petlje na poledini (T. 23: 28/3; 64: 111/2–3);
- Tip 18: brončano žezlo sa stablom djelomično poligonalnog presjeka (T. 25: 33/1);
- Tip 19: šuplje brončane narukvice i nanogvice (npr. T. 97: 1–2; 68);
- Tip 20: debele narebrene masivne brončane narukvice i nanogvice s krajevima koji se dodiruju (npr. T. 24: 1–2; 4: 11–12);
- Tip 21: staklene perle sa slojevitim očima (npr. T. 1: 15; 5: 9/9);
- Tip 22: staklene perle u obliku vaze (npr. T. 55: 98/5–6; 69: 15–21);
- Tip 23: bačvaste staklene perle s dva svitka na krajevima te četiri kuglice u sredini (T. 3: 8);
- Tip 24: staklena perla u obliku vijka (T. 71: 14);
- Tip 25: staklena perla u obliku pršljena za vreteno (T. 55: 98/4);
- Tip 26: iznimno velike spljoštene kuglaste perle jantara (T. 35: 67/2; 91: 9);
- Tip 27: diskoidne perle jantara s urezanim ukrasom (npr. T. 1: 16; 55: 98/18);
- Tip 28: jantarne perle s dodatnim okomitim ili kosim perforacijama (T. 1: 18; 33: 53/1–2; 55: 98/16);
- Tip 29: jantarni privjesci u obliku bule (T. 1: 17; 55: 98/17);
- Tip 30: jantarne pločice – razmaknice (T. 69: 23; 92: 160/15);
- Tip 31: zdjela s naboranim ukrasom tipa 5 prema Dularu (T. 35: 66/1 – Dular 1982: 195, T. 24: 226–232);
- Tip 32: ciboriji tipa 10 prema Dularu (T. 14: 25/14; 33: 50/4; 44: 18 – Dular 1982: 185, T. 17);
- Tip 33: ciborij tipa 11 prema Dularu (T. 50: 12 – Dular 1982: 185, T. 18: 154–156);
- Tip 34: šalica s dvije životinjske glave na ručki tipa 5 prema Dularu (T. 62: 8 – Dular 1982: 192, T. 22: 197–202);
- Tip 35: zdjele na nozi s naboranim ukrasom tipa 2 prema Dularu (npr. T. 33: 50/6; 34: 54/16 – Dular 1982: 196, T. 25: 236–243);
- Tip 36: velika rebrasta cista s dvije ručke sa strane (T. 44: 13).

## NEW LIST OF GRAVES BELONGING TO THE FOURTH PHASE OF BARROW 48 THAT CORRESPONDS TO THE CERTOSA PHASE OF THE DOLENJSKA HALLSTATT GROUP

In my opinion the following 36 graves or finds (22 female, 12 male and 2 undetermined) from barrow 48 can be assigned to the Certosa phase with certainty (Fig. 3):

F (female) 1: Grave 1 (female; depth 3.60 m; Gabrovec 2010: Fig. 21: missing)

F 2: Grave 8 (female; depth 0.30 m; Fig. 21: 4<sup>th</sup> phase)

F 3: Grave 9 (female; depth ?; Fig. 21: missing)

M (male) 1: Find 11 (male; depth ?; Gabrovec 2010: Fig. 21: missing)

M 2: Find 22 (male; depth 3.50 m; Fig. 21: 1<sup>st</sup> phase)

M 3: Grave 25 (male; depth 1.85 m; Fig. 21: missing)

M 4: Grave 28 (male; depth 1.00 m; Fig. 21: missing)

M 5: Grave 33 (male; depth 1.30 m; Fig. 21: missing)

M 6: Grave 34 (male; depth 1.40 m; Fig. 21: missing)

F 4: Grave 43 (female; depth 3.00 m; Fig. 21: missing)

M 7: Grave 49 (male; depth 1.85 m; Fig. 21: missing)

F 5: Grave 50 (female; depth 1.80 m; Fig. 21: 4<sup>th</sup> phase)

F 6: Grave 53 (female; depth 2.75 m; Fig. 21: missing)

M 8: Grave 54 (male; depth 1.40 m; Fig. 21: missing)

X 1: Find 56 (?; depth 1.50 m; Fig. 21: missing)

F 7: Grave 58 (female; depth 1.60 m; Fig. 21: missing)

X 2: Find 66 (?; depth ?; Fig. 21: missing)

F 8: Grave 67 (female; depth ?; Fig. 21: 4<sup>th</sup> phase)

M 9: Grave 76 (male; depth 0.50 m; Fig. 21: missing)

F 9: Grave 85 (female; depth 0.25 m; Fig. 21: 3<sup>rd</sup> phase)

F 10: Find 94 (female; depth 1.76 m; Fig. 21: missing)

F 11: Find 95 (female; depth 1.90 m; Fig. 21: missing)

F 12: Grave 96 (female; depth 1.50 m; Fig. 21: missing)

F 13: Grave 98 (female; depth 1.15 m; Fig. 21: missing; Fig. 23: 4<sup>th</sup> phase)

M 10: Grave 99 (male; depth 0.90 m; Fig. 21: 3<sup>rd</sup> phase)

F 14: Grave 102 (female; depth 0.70 m; Fig. 21: missing)

F 15: Grave 103 (female; depth 0.66 m; Fig. 21: 4<sup>th</sup> phase)

M 11: Grave 104 (male; depth 0.55 m; Fig. 21: missing; Fig. 23: 4<sup>th</sup> phase)

F 16: Find 107 (female; depth -0.30 to -0.60 m; Fig. 21: missing)

M 12: Grave 111 (male; depth -1.60 m; Fig. 21: missing)

F 17: Grave 119–120 (female; depth 3.25 m; Fig. 21: 4<sup>th</sup> phase)

F 18: Grave 121 (female; depth 2.00 m; Fig. 21: missing)

F 19: Grave 160 (female; depth -0.80 m; Fig. 21: missing)

F 20: Find 168 (female?; depth 1.70 m; Fig. 21: missing)

F 21: Grave 169 (female; depth 0.80 m; Fig. 21: 4<sup>th</sup> phase)

F 22: Grave 170 (female?; depth 1.10 m; Fig. 21: missing).

We can see that out of 36 graves from the Certosa phase Gabrovec in Figures 21 and 23 only ascribed eight to his 4<sup>th</sup> phase, which should correspond to the Certosa phase, while two (85 and 99) were wrongly attributed to his 3<sup>rd</sup> phase, and one (find 22) was even more wrongly assigned to the 1<sup>st</sup> phase. He assigned in text (Gabrovec 2010: 55), however, 10

## NOVI POPIS GROBOVA KOJI PRIPADAJU ČETVRTOJ FAZI TUMULA 48, KOJA ODGOVARA CERTOŠKOM STUPNJU DOLENJSKE HALŠTATSKE SKUPINE

Po mom mišljenju, sljedećih 36 grobova ili nalaza (22 ženska, 12 muških te 2 neodređena) iz tumula 48 mogu se sa sigurnošću pripisati certoškom stupnju (sl. 3):

F (female – ženski) 1: Grob 1 (ženski; dubina 3,60 m; Gabrovec 2010: sl. 21: nedostaje)

F 2: Grob 8 (ženski; dubina 0,30 m; sl. 21: 4. faza)

F 3: Grob 9 (ženski; dubina ?; sl. 21: nedostaje)

M (male – muški) 1: Nalaz 11 (muški; dubina ?; Gabrovec 2010: sl. 21: nedostaje)

M 2: Nalaz 22 (muški; dubina 3,50 m; sl. 21: 1. faza)

M 3: Grob 25 (muški; dubina 1,85 m; sl. 21: nedostaje)

M 4: Grob 28 (muški; dubina 1,00 m; sl. 21: nedostaje)

M 5: Grob 33 (muški; dubina 1,30 m; sl. 21: nedostaje)

M 6: Grob 34 (muški; dubina 1,40 m; sl. 21: nedostaje)

F 4: Grob 43 (ženski; dubina 3,00 m; sl. 21: nedostaje)

M 7: Grob 49 (muški; dubina 1,85 m; sl. 21: nedostaje)

F 5: Grob 50 (ženski; dubina 1,80 m; sl. 21: 4. faza)

F 6: Grob 53 (ženski; dubina 2,75 m; sl. 21: nedostaje)

M 8: Grob 54 (muški; dubina 1,40 m; sl. 21: nedostaje)

X 1: Nalaz 56 (?; dubina 1,50 m; sl. 21: nedostaje)

F 7: Grob 58 (ženski; dubina 1,60 m; sl. 21: nedostaje)

X 2: Nalaz 66 (?; dubina ?; sl. 21: nedostaje)

F 8: Grob 67 (ženski; dubina ?; sl. 21: 4. faza)

M 9: Grob 76 (muški; dubina 0,50 m; sl. 21: nedostaje)

F 9: Grob 85 (ženski; dubina 0,25 m; sl. 21: 3. faza)

F 10: Nalaz 94 (ženski; dubina 1,76 m; sl. 21: nedostaje)

F 11: Nalaz 95 (ženski; dubina 1,90 m; sl. 21: nedostaje)

F 12: Grob 96 (ženski; dubina 1,50 m; sl. 21: nedostaje)

F 13: Grob 98 (ženski; dubina 1,15 m; sl. 21: nedostaje; sl. 23: 4. faza)

M 10: Grob 99 (muški; dubina 0,90 m; sl. 21: 3. faza)

F 14: Grob 102 (ženski; dubina 0,70 m; sl. 21: nedostaje)

F 15: Grob 103 (ženski; dubina 0,66 m; sl. 21: 4. faza)

M 11: Grob 104 (muški; dubina 0,55 m; sl. 21: nedostaje; sj. 23: 4. faza)

F 16: Nalaz 107 (ženski; dubina -0,30 do -0,60 m; sl. 21: nedostaje)

M 12: Grob 111 (muški; dubina -1,60 m; sl. 21: nedostaje)

F 17: Grob 119–120 (ženski; dubina 3,25 m; sl. 21: 4. faza)

F 18: Grob 121 (ženski; dubina 2,00 m; sl. 21: nedostaje)

F 19: Grob 160 (ženski; dubina -0,80 m; sl. 21: nedostaje)

F 20: Nalaz 168 (ženski?; dubina 1,70 m; sl. 21: nedostaje)

F 21: Grob 169 (ženski; dubina 0,80 m; sl. 21: 4. faza)

F 22: Grob 170 (ženski?; dubina 1,10 m; sl. 21: nedostaje).

Možemo vidjeti da je od 36 grobova iz certoškoga stupnja Gabrovec na slikama 21 i 23 tek njih osam pripisao svojoj 4. fazi, koja bi odgovarala certoškom stupnju, dok su dva (85 i 99) pogrešno pripisana njegovoj 3. fazi, a jedan (nalaz 22)

graves with serpentine fibulae to his 4<sup>th</sup> phase, which is also incorrect. Seven of these should in reality be dated to the 3<sup>rd</sup> phase. Serpentine fibulae are only present in three graves of the fourth phase (34, 54 and 76), all of them male. They do not belong to the types characteristic for the preceding Serpentine Fibulae phase, but rather to later types. Equally wrong, as already mentioned, is his attribution of finely or somewhat strongly ribbed bracelets with tapered overlapping ends to this phase, while they are also a typical feature of the Serpentine Fibulae phase. Of the 36 different types of finds from the Certosa phase listed above, he only cited Certosa fibulae (types 1–3), a three-knobbed fibula (type 4), fibulae with an animal bow (types 5 and 6), hollow bracelets (type 19) and thick ribbed solid bracelets with touching ends (type 20) correctly, the fibulae, however, not in detail, and nothing else, no weapons, no metal parts of the warrior belts, no horse gear, no glass and amber beads, no pottery and no bronze vessels.

### FINAL THOUGHTS

The publication of the studies dealing with the Hallstatt graves from Stična was a very good opportunity to prepare an excellent scientific work, which would contain a modern, well-founded, and reliable presentation of many aspects of the Dolenjska Hallstatt group. It should not be forgotten that the chronology of the Dolenjska group is also of crucial importance for the neighbouring states: Italy, Austria, Hungary, Croatia, and Bosnia and Herzegovina. The authors might have achieved this, since the significance of barrow 48 lies in the fact that despite many problems with its long excavation (from 1946 to 1964) it provides an extremely clear picture of the development of the material culture from the Stična 2 phase to the Certosa 2 phase.

In the future every archaeologist dealing with the Hallstatt culture of Dolenjska should base his research primarily on the well excavated and relatively well published barrows from Stična (48 and 5 – Gabrovec 2006), on the barrows from Novo mesto (from the sites of Znančeve njive and Kapiteljska njiva – Knez 1986; 1993; Križ 1997; 2000; 2013) and on some other barrows (e.g., from Volčje Njive and from Mačkovec near Novo mesto – Gabrovec 1956; Udovč, Leben Seljak 2009). From the cemeteries excavated for the museums in Ljubljana and Vienna before World War I, only the reliable grave groups should be considered.

As I have shown in two papers from 2009 and 2010 (Božič 2009; 2010), the grave groups from Magdalenska gora and from Stična excavated by the Duchess of Mecklenburg and presented in the scientific monographs in 1978 (written by H. Hencken) and in 1981 (written by P. S. Wells), are almost worthless for scientific research. Since they were published many Slovene and foreign archaeologists have based their studies on these mixed graves, and because of this it is understandable that the results of their research are wrong to a large extent! Let me cite only five works, which were negatively influenced by the misleading mixed grave groups from Magdalenska gora and Stična, presented in Hencken and Wells' books: Dular's book on Hallstatt pottery in Slovenia (Dular 1982), Egg's book on Italic helmets (Egg

je, što je još veća greška, pripisan 1. fazi. U tekstu (Gabrovec 2010: 55), dapače, je deset grobova sa zmijolikim fibulama pripisao svojoj 4. fazi, što je također pogrešno. Sedam od tih grobova treba uistinu datirati u 3. fazu. Zmijolike fibule prisutne su samo u tri groba četvrte faze (34, 54 i 76), a sva su tri muška. Ne pripadaju tipovima koji su karakteristični za prethodni stupanj zmijolikih fibula nego kasnijim tipovima. Jednako je pogrešna, kako je već napomenuto, njegova atribucija fino ili nešto jače narebrenih narukvica sa suženim preklapljenim krajevima ovoj fazi, jer su one isto tako tipičan oblik stupnja zmijolikih fibula. Od 36 različitih tipova nalaza iz certoškoga stupnja koji su gore pobrojani, on je samo certoške fibule (tipove 1–3), fibulu s tri dugmeta na luku (tip 4), fibule sa životinjskim lukom (tipovi 5 i 6), šuplje narukvice (tip 19) te debele narebrene masivne narukvice s krajevima koji se dodiruju (tip 20) naveo ispravno, međutim, fibule nije naveo detaljno, a k tomu nije naveo ništa drugo – oružje, metalne dijelove ratničkih pojaseva, konjsku opremu, staklene ili jantarne perle, keramiku i brončano posuđe.

### ZAVRŠNA RAZMIŠLJANJA

Objava studija koje se bave halštatskim grobovima iz Stične predstavljala je vrlo dobru priliku da se pripremi izvrsan znanstveni rad koji bi na suvremen, utemeljen i pouzdan način predstavio brojne aspekte dolenske halštatske skupine. Ne bi trebalo zaboraviti da je kronologija dolenske skupine također od velike važnosti za susjedne države: Italiju, Austriju, Mađarsku, Hrvatsku te Bosnu i Hercegovinu. Autori su to mogli postići, s obzirom na to da značenje tumula 48 leži u činjenici da, usprkos brojnim problemima s dugotrajnim iskopavanjem toga tumula (od 1946. do 1964.), on pruža iznimno jasnu sliku razvoja materijalne kulture od stupnja Stična 2 do certoškoga stupnja 2.

Ubuduće bi svaki arheolog koji se bavi halštatskom kulturom Dolenjske trebao temeljiti svoja istraživanja prije svega na dobro iskopanim i razmjerno dobro objavljenim tumulima iz Stične (48 i 5 – Gabrovec 2006), na tumulima iz Novog Mesta (sa Znančevih njiva i Kapiteljske njive – Knez 1986; 1993; Križ 1997; 2000; 2013) te na još nekim tumulima (npr. iz Volčjih Njiva te iz Mačkovca kraj Novog Mesta – Gabrovec 1956; Udovč, Leben Seljak 2009). S globalja koja su za muzeje u Ljubljani i Beču iskopavana prije Prvoga svjetskog rata, mogu se uzeti u obzir samo pouzdane grobne cjeline.

Kao što sam pokazao u dva članka iz 2009. i 2010. godine (Božič 2009; 2010), grobne cjeline s Magdalenske gore i iz Stične koje je istražila vojvotkinja Mecklenburg te koje su objavljene u znanstvenim monografijama iz 1978. (koju je napisao H. Hencken) te 1981. (napisao P. S. Wells), gotovo su bez ikakve vrijednosti za znanstveno-istraživački rad. Od objave ovih publikacija, brojni slovenski i strani arheolozi temeljili su svoja proučavanja na ovim pomiješanim grobovima, a zbog toga je razumljivo da su i rezultati njihovih istraživanja u velikoj mjeri pogrešni! Ovdje ću navesti samo pet djela na koja su imale negativan utjecaj pomiješane grobne cjeline s Magdalenske gore i iz Stične koje su publicirali Hencken i Wells: Dularova knjiga o halštatskoj keramici

1986), Parzinger's book on chronology (Parzinger 1988), the *Stična II/2* book (Gabrovec, Teržan 2010), and even the monograph on the Magdalenska gora Hallstatt barrows (Tecco Hvala 2012).

Contrary to expectations Stane Gabrovec and Biba Teržan, both prehistorians renowned not only in Slovenia but also abroad, both professors in the Department of Archaeology at the Faculty of Arts of the University of Ljubljana, and both members of the Slovenian Academy of Sciences and Arts, have written rather problematic texts for a book, which in this form should not have appeared in *Katalogi in monografije*, the most important archaeological series in Slovenia, although it contains also some valuable contributions! Nothing else remains but to start to prepare a new one. Above I have demonstrated as a case study the high potential of the graves from barrow 48 for a typological and chronological analysis of the Certosa phase of the Dolenjska Hallstatt group.

### Acknowledgement

I am very much grateful to Emily Zavodny, doctoral student at the Penn State University (USA), for the very careful proofreading of the paper, and to my co-worker Drago Valoh, who elaborated Figs. 1 and 3 as well as Pls. 1–4.

iz Slovenije (Dular 1982), Eggova knjiga o italskim kacigama (Egg 1986), Parzingerova knjiga o kronologiji (Parzinger 1988), publikacija *Stična II/2* (Gabrovec, Teržan 2010), pa čak i monografija o halštatskim tumulima s Magdalenske gore (Tecco Hvala 2012).

U suprotnosti s očekivanjima, Stane Gabrovec i Biba Teržan, oboje prapovjesničari cijenjeni ne samo u Sloveniji nego i u inozemstvu, oboje profesori na Odjelu za arheologiju na Filozofskom fakultetu Sveučilišta u Ljubljani te oboje članovi Slovenske akademije znanosti i umjetnosti, napisali su prilično problematične tekstove za knjigu, koja se u tom obliku nije smjela pojaviti u *Katalogi in monografije*, najvažnijoj arheološkoj seriji u Sloveniji, iako sadrži i neke vrijedne priloge! Ne preostaje ništa drugo nego započeti s pripremanjem nove publikacije. Prethodno sam kroz *case study* pokazao koliko je velik potencijal grobova iz tumula 48 za tipološku i kronološku analizu certoškoga stupnja dolenjske halštatske skupine.

### Zahvale

Najljepše zahvaljujem Emily Zavodny, doktorandici Sveučilišta Penn State (SAD) na vrlo pažljivoj lekturi članka, kao i svom suradniku Dragi Valohu na razradi sl. 1 i 3 te tabli 1–4.

Prijevod / Translation  
Dragan Božič  
Sanjin Mihelić

Lektura / Proofreading  
Emily Zavodny



## BIBLIOGRAPHY / LITERATURA

- Božič, D. 2009, A Hallstatt grave containing a cuirass, excavated near Stična by the Duchess of Mecklenburg in 1913 / K halštatskemu grobu z oklepom, ki ga je leta 1913 pri Stični izkopala vojvodinja Mecklenburška, *Arheološki vestnik*, Vol. 60, 63–95.
- Božič, D. 2010, Zum Panzergrab von Stična und der Verlässlichkeit der Grabzusammenhänge in der Sammlung Mecklenburg, *Acta Praehistorica et Archaeologica*, Vol. 42, 155–172.
- Božič, D. 2015, Zur Herkunft und Datierung eines singulären Tüllenbeiles aus der Sammlung Magajna, in: *Beiträge zur Hallstattzeit am Rande der Südostalpen*, Gutjahr, Ch., Tiefengraber, G. (eds.), Internationale Archäologie. Arbeitsgemeinschaft, Symposium, Tagung, Kongress 19, Rahden/Westf., 135–149.
- Dular, J. 1982, *Halštatska keramika v Sloveniji / Die Grabkeramik der älteren Eisenzeit in Slowenien*, Dela 1. razreda SAZU 23/12, Ljubljana.
- Dular, J. 2003, *Halštatske nekropole Dolenjske / Die hallstattzeitlichen Nekropolen in Dolenjsko*, Opera Instituti Archaeologici Sloveniae 6, Ljubljana.
- Egg, M. 1986, *Italische Helme*, Monographien – Römisch-Germanisches Zentralmuseum 11, Mainz.
- Gabrovec, S. 1956, Ilirska gomila v Volčjih njivah / The Illyrian tumulus at Volčje njive, *Arheološki vestnik*, Vol. 7, 62–130.
- Gabrovec, S. 1987, Dolenjska grupa, in: *Praistorija jugoslavenskih zemalja V. Željezna doba*, Gabrovec S. (ed.), Sarajevo, 29–119.
- Gabrovec, S. 2006, *Stična II/1. Gomile starejše železne dobe / Grabhügel aus der älteren Eisenzeit. Katalog*, Katalogi in monografije 37, Ljubljana.
- Gabrovec, S. 2010, *Stiške gomile / Stična – Grabhügel*, in: Gabrovec, S., Teržan, B. 2010, *Stična II/2. Gomile starejše železne dobe. Razprave / Grabhügel aus der älteren Eisenzeit. Studien*, Ljubljana, 7–60.
- Gabrovec, S., Teržan, B. 2010, *Stična II/2. Gomile starejše železne dobe. Razprave / Grabhügel aus der älteren Eisenzeit. Studien*, Katalogi in monografije 38, Ljubljana.
- Hencken, H. 1978, *Mecklenburg Collection 2. The Iron Age Cemetery of Magdalenska gora in Slovenia*, Bulletin – American School of Prehistoric Research 32, Cambridge, MA.
- Knez, T. 1986, *Novo mesto I. Halštatski grobovi / Hallstattzeitliche Gräber*, Carniola archaeologica 1, Novo mesto.
- Knez, T. 1993, *Novo mesto III. Kapiteljska njiva. Knežja gomila / Fürstengrabhügel*, Carniola archaeologica 3, Novo Mesto.
- Križ, B. 1997, *Novo mesto IV. Kapiteljska njiva. Gomila II in gomila III / Barrow II and barrow III*, Carniola archaeologica 4, Novo Mesto.
- Križ, B. 2000, *Novo mesto V. Kapiteljska njiva. Gomila IV in gomila V / Barrow IV and barrow V*, Carniola archaeologica 5, Novo Mesto.
- Križ, B. 2013, *Novo mesto VII. Kapiteljska njiva. Gomile I, XIV in XV / Barrows I, XIV and XV*, Carniola archaeologica 7, Novo Mesto.
- Ogrin, M. 1998, Trortasta fibula v Sloveniji / Die Dreiknopffibel in Slowenien, *Arheološki vestnik*, Vol. 49, 101–132.
- Parzinger, H. 1988, *Chronologie der Späthallstatt- und Frühlatène-Zeit*, Quellen und Forschungen zur prähistorischen und provinzialrömischen Archäologie 4, Weinheim.
- Tecco Hvala, S. 2012, *Magdalenska gora*, Opera Instituti Archaeologici Sloveniae 26, Ljubljana.
- Tecco Hvala, S. 2014, Kačaste fibule z območja Slovenije / Serpentine fibulae from Slovenia, *Arheološki vestnik*, Vol. 65, 123–186.
- Teržan, B. 1976, Certoška fibula / Die Certosafibel, *Arheološki vestnik*, Vol. 27, 317–536.
- Teržan, B. 2010, *Stiške skice / Stična – Skizzen*, in: Gabrovec, S., Teržan, B. 2010, *Stična II/2. Gomile starejše železne dobe. Razprave / Grabhügel aus der älteren Eisenzeit. Studien*, Ljubljana, 189–325.
- Udovč, K., Leben Seljak, P. 2009, *Mačkovec pri Novem mestu*, Ljubljana.
- Wells, P. S. 1981, *Mecklenburg Collection 3. The Emergence of an Iron Age Economy*, Bulletin – American School of Prehistoric Research 33, Cambridge, MA.

Pl. 1

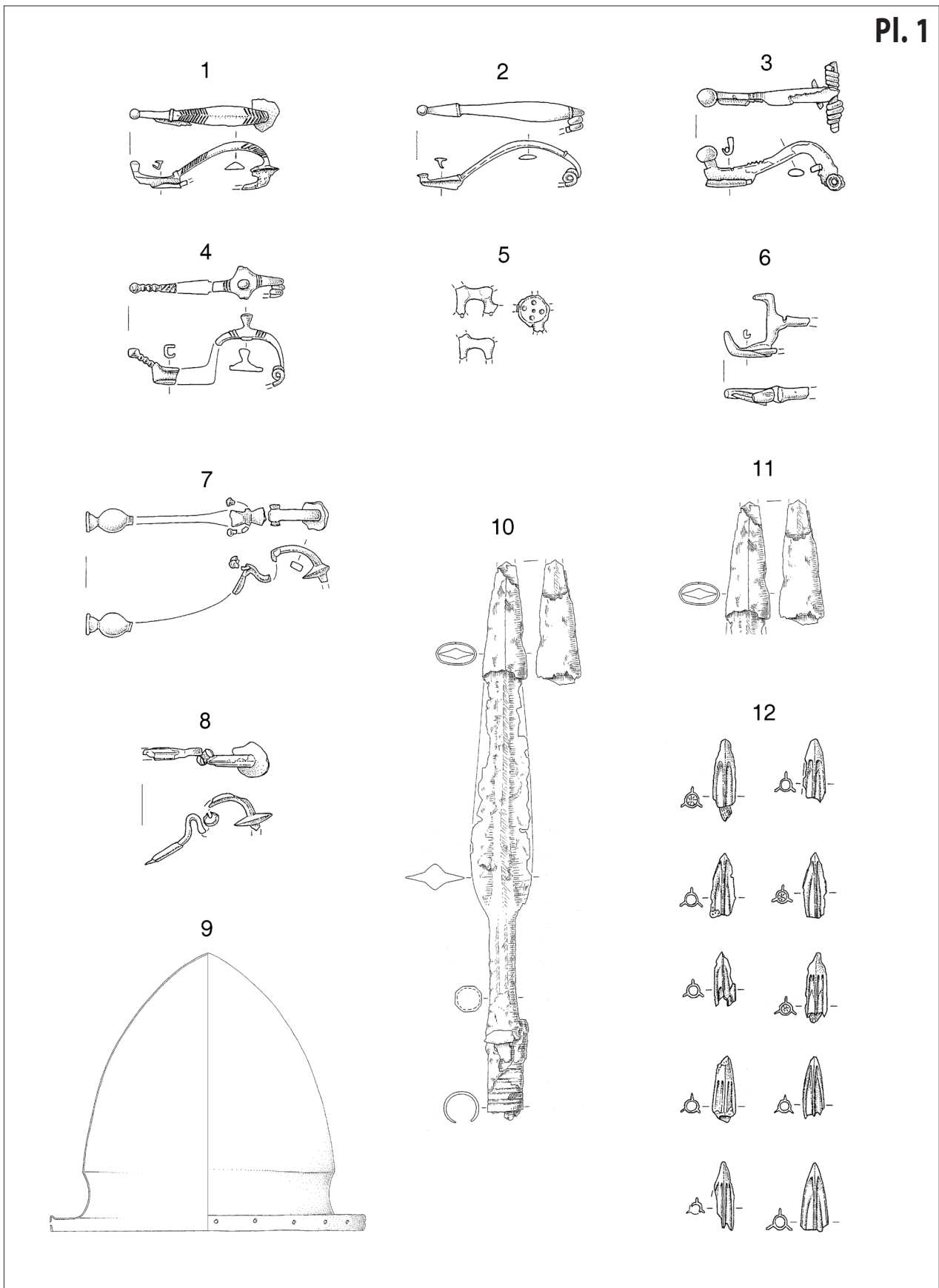

Pl. 1 Types of finds in the Certosa phase graves from barrow 48 at Stična (Gabrovec 2006): type 1 – type 12

T. 1 Tipovi nalaza certoške faze grobova iz tumula 48 u Stični (Gabrovec 2006): tip 1 – tip 12

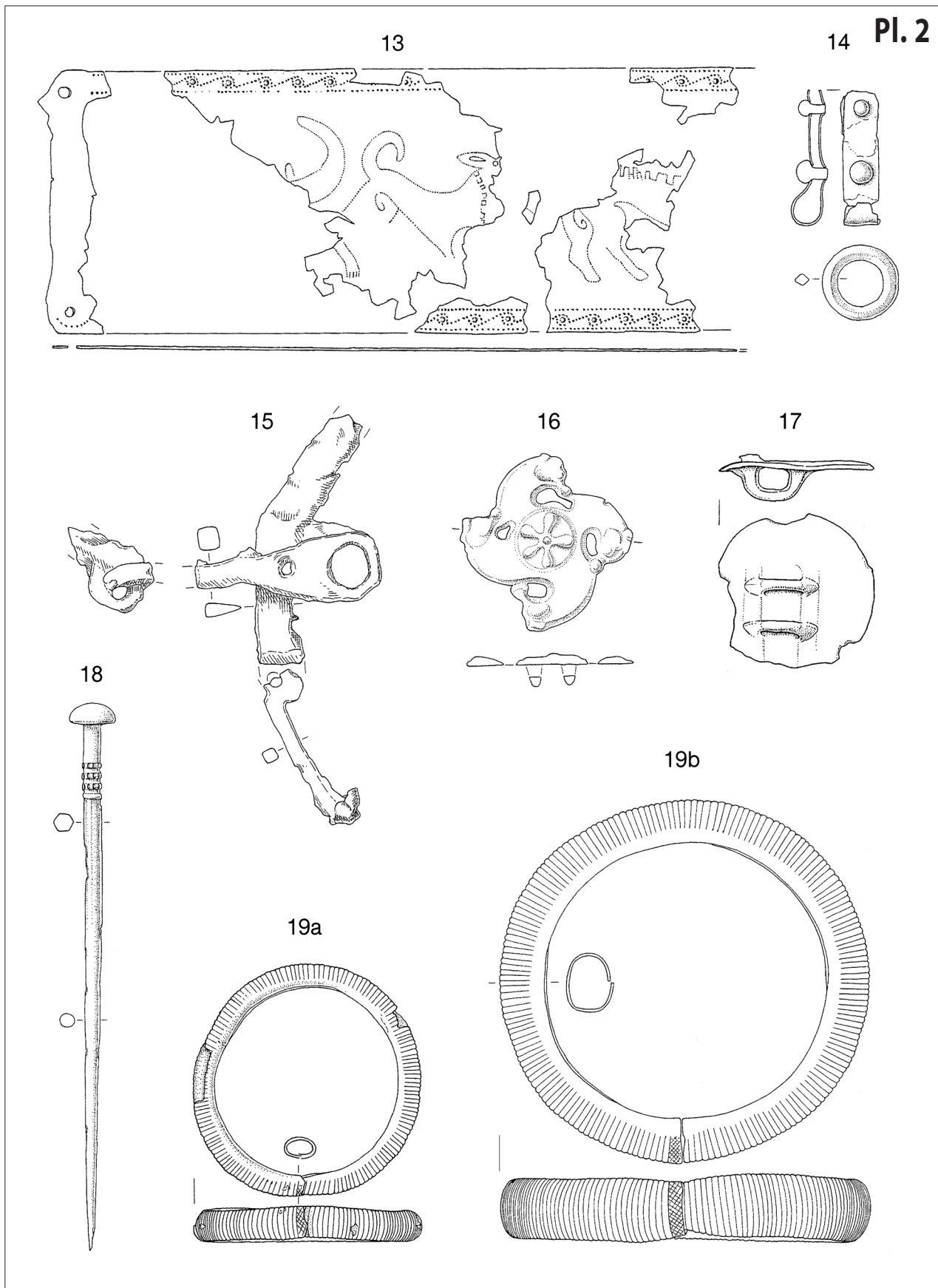

Pl. 2 Types of finds in the Certosa phase graves from barrow 48 at Stična (Gabrovec 2006): type 13 – type 19  
T. 2 Tipovi nalaza certoške faze grobova iz tumula 48 u Stični (Gabrovec 2006): tip 13 – tip 19

Pl. 3

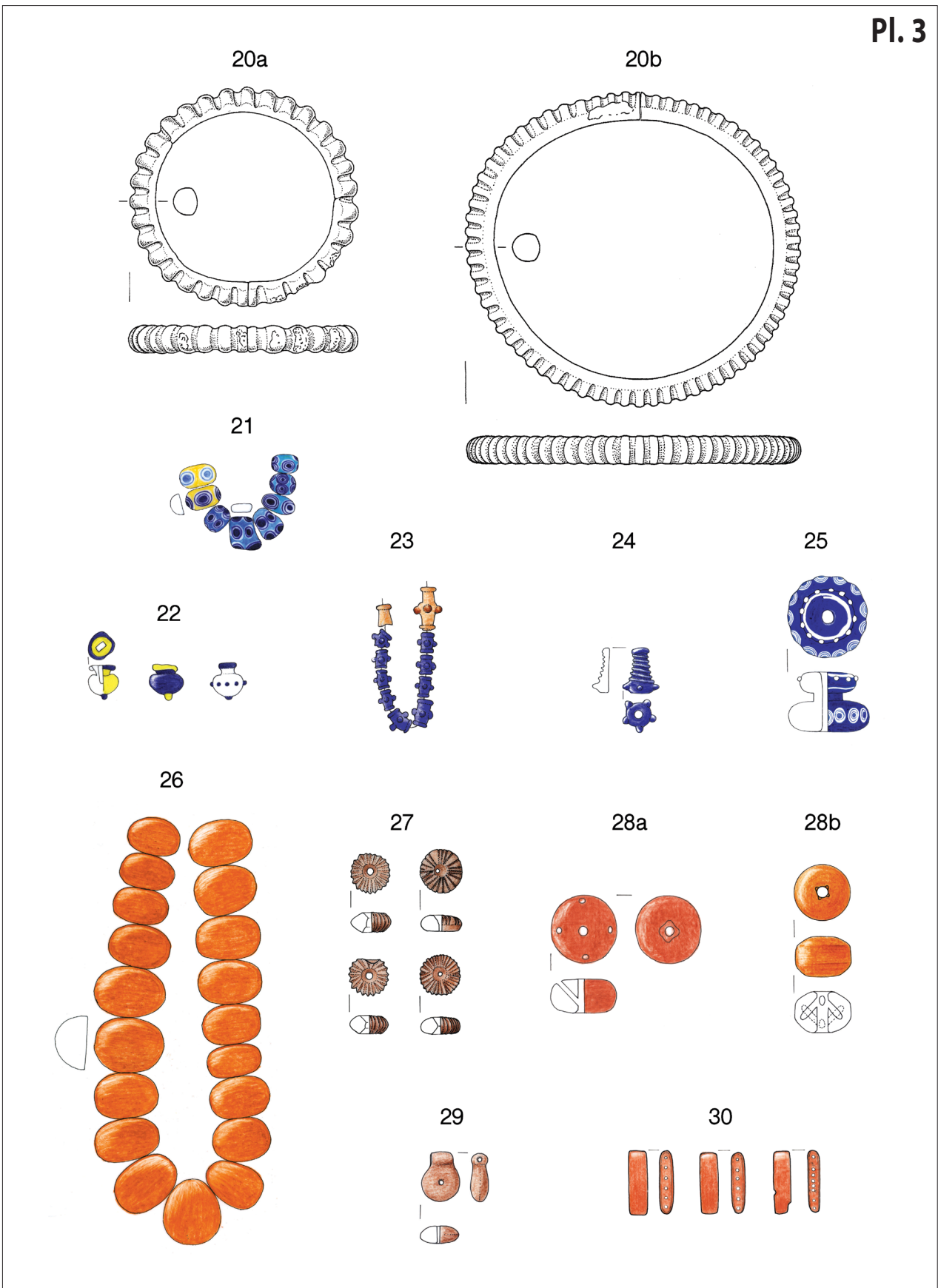

Pl. 3 Types of finds in the Certosa phase graves from barrow 48 at Stična (Gabrovec 2006): type 20 – type 30  
T. 3 Tipovi nalaza certoške faze grobova iz tumula 48 u Stični (Gabrovec 2006): tip 20 – tip 30

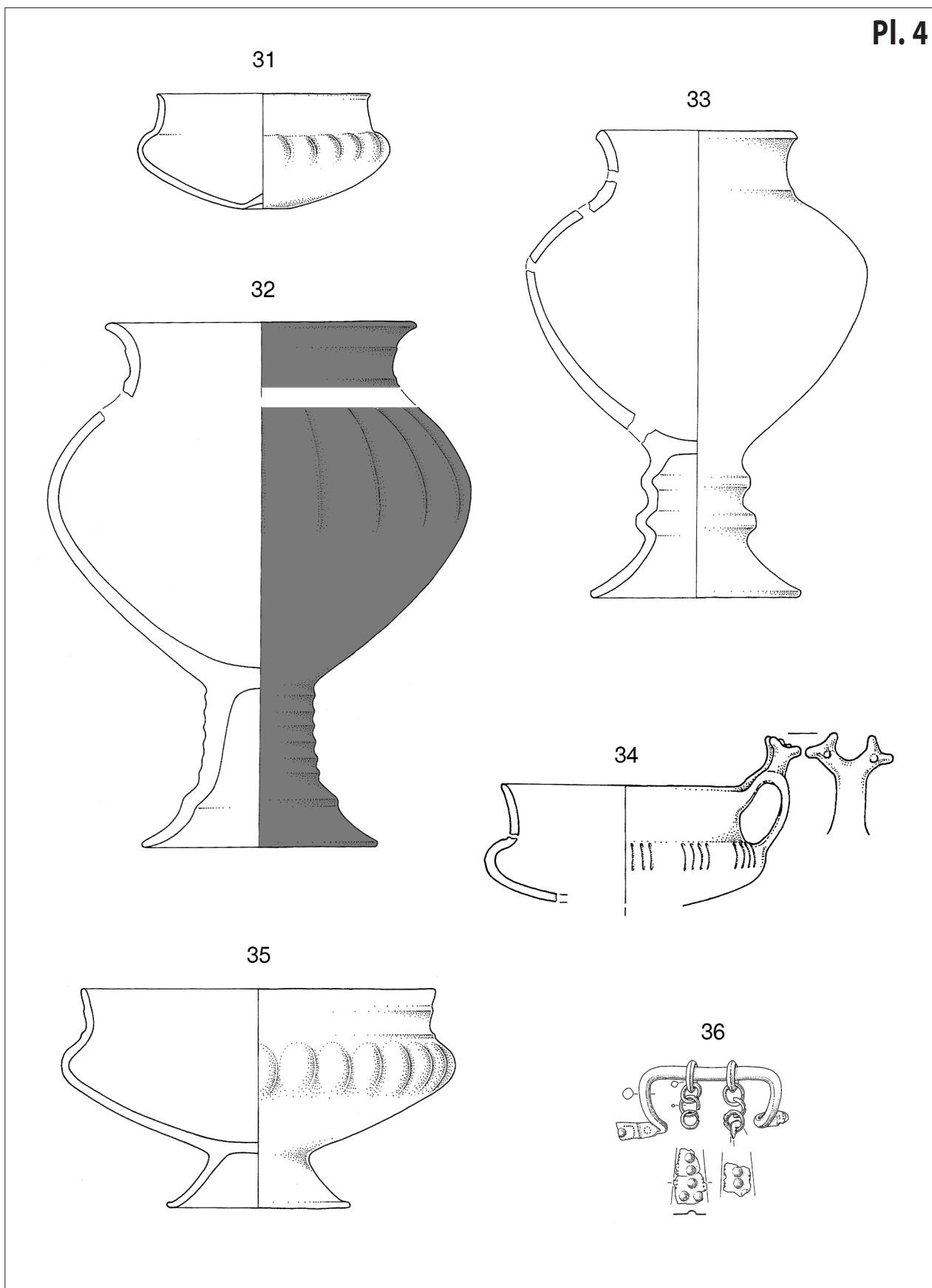

Pl. 4 Types of finds in the Certosa phase graves from barrow 48 at Stična (Gabrovec 2006): type 31 – type 36  
T. 4 Tipovi nalaza certoške faze grobova iz tumula 48 u Stični (Gabrovec 2006): tip 31 – tip 36